



## 2025 Stock Car Rules

### **DISCLAIMER:**

The rules and/or **regulations** set forth herein are designed to provide for the orderly conduct of racing events and to establish minimum acceptable requirements for such events. These rules shall govern the condition of all events, and, by participating in these events, all participants are deemed to have complied with these rules. *No expressed or implied warranty of safety shall result from the publication of or compliance with these rules and/or regulations.* They are intended as a guide for the conduct of the sport and in no way a guarantee against injury or death to a participant, spectator, or official.

The race director shall be empowered to permit reasonable and appropriate deviation from any of the specifications herein or impose any further restrictions that in his opinion do not alter the minimum acceptable requirements. *No expressed or implied warranty of safety shall results from such alterations of specifications.* Any interpretation or deviation of these rules is left to the discretion of the officials. Their decision is final.

On occasion when situations arise that are not covered by written rules, special rulings may be put into effect by the Series of Track Officials. Once such rulings are acted upon, they *may* be added to the existing rules and/or procedures.

### **Contact Info:**

RUSH Racing Series Directors: Vicki Emig & Mike Leone  
4368 US 422, Pulaski, PA 16143  
724-964-9300 (phone)  
E-mail: [info@rushracingseries.com](mailto:info@rushracingseries.com)

Tommy Fox (Competition Director) 716-487-7392  
E-mail: [tom.fox2014@outlook.com](mailto:tom.fox2014@outlook.com)

Website: [www.rushstockcars.com](http://www.rushstockcars.com)  
Like us on Facebook at [www.facebook.com/rushstockcars](http://www.facebook.com/rushstockcars)  
Follow us on Twitter @RUSHStockCars

**The following guidelines shall be considered the "Official Rules and Specifications" for all events sanctioned by the RUSH Stock Car Series.**

**CHAMPIONSHIP SERIES:**

**Weekly Series:**

You must be a Weekly Series member to be eligible for point fund monies (\$125 annual membership). Points will be accumulated for drivers' best 12 point scores throughout the season at RUSH-sanctioned events only. POINTS ARE NOT RETROACTIVE. YOUR POINTS WILL NOT COUNT UNTIL MEMBERSHIP IS COMPLETED & PAID! Membership forms are available at the following link <https://rushstockcars.com/memberships.html> or can be purchased through the Pit Pay App <https://getpitpay.com/5lb>. RUSH reserves the right to decline a membership or revoke a membership at any time.

**Points Fund (\$7,495):** 1. \$2,000 2. \$1,000 3. \$750 4. \$500 5. \$400 6. \$350 7. \$325 8. \$300 9. \$290 10. \$280 11. \$270 12. \$265 13. \$260 14. \$255 15. \$250

**"Futures Cup":** (\$300 to-win; remainder of point fund TBA based on participation)

Must be a Weekly member, not be older than 19 years of age (cannot turn 20 before July 1), and not be a prior "Futures Cup" Champion to be eligible for points and point fund monies. Those 18 & 19 cannot have more than 1 prior season of Stock Car experience (8 or more events = 1 season). No headlining division experience permitted. Those under 16 should verify eligibility to race at each individual track. Points are based off Weekly Series Championship.

**Point Fund Clause:**

In the event of unforeseen circumstances, the RUSH Racing Series reserves the right to adjust any and all point funds.

**"Manufacturers Night" presented by MSD Performance:**

A Manufacturers Night will be held at a location and date TBA where several thousands of dollars of products will be given away. Driver's car MUST be 100% RUSH legal and attempt to compete in the night's racing program.

**Insurance:**

Members receive \$100,000 excess participant accident insurance. Policy period is 1/1/25-1/1/26; however, coverage does not begin until membership is completed and paid. RUSH insurance benefits will cover the member driver after the tracks participant accident limit and driver's individual health insurance benefits are exhausted, but only at RUSH-sanctioned events.

**Point System:**

The following system will be utilized for all of the above programs: 1. 100 2. 98 3. 96 4. 94 5. 92 6. 90 7. 89 8. 88 9. 87 10. 86 11. 85 12. 84 13. 83 14. 82 15. 81 16. 80 17. 79 18. 78 19. 77 20. 76 21. 75 22. 74 23. 73 24. 72 25 & any other starter 71. Drivers attempting to race, but not starting the feature will receive 70 show-up points. On Weekly Series events, all drivers will receive 12 "bonus" points provided there are 12 or more cars. If there are less than 12 cars, the car count bonus will be based on number of competing cars signed in.

*Postponed feature events will revert back to the weekend they were initially scheduled for with the exception of an event that has been pushed to the following year.*

**Awards Banquet/Point Funds/Tie-Breakers:**

A RUSH Racing Series Awards Banquet will be held at the conclusion of the season (January/February). Drivers/Car Owners are expected to attend or have a pre-determined representative to accept awards. Unclaimed payoffs and awards will be mailed at a later date.

*In the event of a tie for the Weekly Series or Futures Cup Championships, tiebreaker will be determined by the driver with the most high point scores followed by most second high point scores, etc. until the tie is broken (in essence most 112's, most 111's, most 110's, etc). If a tie happens in any other position, the tie will remain with point fund monies added up between the tied positions and split equally.*

## **ELIGIBILITY:**

### **Drivers will be ineligible to compete if any one of the following apply:**

- Driver is a full-time competitor in any of the following divisions: Super Late Models, Steel-Block Late Models, "410" Sprint Cars, Big-Block Modifieds, "358" Modifieds or UMP Modifieds. Full-time equals 10 or more races in any of the above or combination of the above. Once driver reaches the point, he/she will be unable to compete for the balance of the season and will lose accumulated RUSH points for the year, if applicable.
- Driver is a top 5 point finisher in any of the following divisions: Super Late Models, Steel-Block Late Models, "410" Sprint Cars, Big-Block Modifieds, "358" Modifieds or UMP Modifieds in the past 2 seasons (excludes current season).
- Driver is a feature winner or champion in the past 2 seasons in any of the following divisions: Super Late Models, Steel-Block Late Models, "410" Sprint Cars, Big-Block Modifieds, "358" Modifieds or UMP Modifieds.

Final driver eligibility to be determined by RUSH Series and/or Speedway Promoters to ensure the intent, growth, and stability of the RUSH Stock Car division.

## **AGE REQUIREMENTS:**

Age requirements vary by speedway. It is the team's responsibility to verify eligibility.

## **PAYOFF:**

While the RUSH Series makes every effort to sanction and/or schedule events at reputable facilities, and has never had any problems with purse payouts to competitors, please be aware that RUSH cannot be responsible in the event that a promoter fails to make purse payments, or pays with checks which are later found to be not negotiable. This notice includes the possible situation where a promoter might pay the full purse to RUSH with a check that is later to be insufficient. RUSH will not pay purse payments until promoter's check clears. When speedway and/or promoter's check clears, RUSH will then guarantee proper purse payments, subject only to resolution of protests, or technical infractions.

RUSH Series Officials reserve the right to hold payoff(s) of driver(s) selected for technical inspection(s). Payoffs will only be released to 1099 recipient(s) of selected driver(s) upon final technical inspection results and/or appeal process providing said inspection complies with RUSH Technical Rules. In the event selected driver(s) technical inspection results does not comply with RUSH Technical Rules and appeals process has been exhausted, said payoff will be adjusted and distributed to other competing racers.

RUSH Series Officials also reserves the right to withhold a driver's payoffs in the event said driver has a debt to the Series.

RUSH will mail the person or corporation designated on the membership form any purse or point fund payoffs. In the event of a car owner change, a new membership form must be completed. In the event of a car owner change midseason, point fund payoffs would be prorated based on performance in all point funds (based on the program's specs, i.e. best 12 finishes) other than Touring, which has a separate driver/owner point fund. A Form 1099 MISC by January 31 of the following year will be sent to the person or corporation that earned a minimum of \$600.00 during the year for any monies paid by Great Crate Racing Northeast, LLC D/B/A RUSH Racing Series, as required by the IRS.

## **SERIES' SPONSOR PRODUCT CONTINGENCIES AND DECALS:**

The RUSH Stock Car Series decal is required on both sides of the car. Sponsor decal package/logos link for body graphics usage is located at the bottom of the website sponsor page.

Required RUSH Series sponsor decals must be displayed prominently on both sides of the car at all events. Your car may be checked for decals at any time.

Certain product manufacturers award contingency product and/or money. The awards are dependent upon the manufacturers decal being displayed on the racecar. To be eligible to receive the award from the manufacturers concerned, it is your responsibility to ensure that the correct decal is affixed to your racecar.

Please be aware that the Series' has no responsibility to pay the award, but only to provide the participant with the certificate previously agreed upon and contracted with the Manufacturer.

Contingency prizes will be awarded to the car owner of record. It is the responsibility of the participant to redeem contingency prize certificates and/or product by expiration date on certificate. Series will not be responsible for delivery and/or transportation of contingency prizes that were not available for pick-up on event date.

Keep in mind that sponsors only put money into the Series to gain exposure for their products; no exposure will eventually mean no money and smaller championship programs.

RUSH Racing Series Officials may refuse to allow a participant to compete in an event if it is determined at their discretion that any advertising and/or sponsorship or similar agreement is **detrimental** to the sport, the RUSH Racing Series, or the event promoter for any reason, including the image of the sport.

### **CONDUCT:**

***At RUSH Weekly Sanctioned events, the racing procedures and track conduct will be administered and enforced by track management and officials.***

- A.) All drivers, crew chiefs, car owners, crew members and/or team representatives agree to act in a professional manner as determined by RUSH Officials. The professional manner includes, but is not limited to verbal representation, written representation, any representation that may represent the RUSH Racing Series, sport of Late Model racing and/or motorsports in general and/or any affiliates. Verbal and/or physical abuse towards a RUSH Series Official may result in an immediate disqualification and/or fine and/or suspension and/or legal action and/or other action deemed appropriate by RUSH Series Officials.
- B.) Any driver or car owner that disparages RUSH in any publication, including all forms of social media and public forums may be subject to a fine and/or suspension and/or legal action and/or any other action deemed appropriate by RUSH Series Officials.
- C.) Any driver, during an event; a competitor, crew chief, car owner, crew member and/or team representative may be requested to report for consultation and/or technical inspection with RUSH Officials. The request may be communicated over the one-way radio and/or verbally. Failure to comply with the request will be subject to disqualification, possible fine and/or suspension and/or any other action deemed appropriate by RUSH Officials.

Participants grant and assign to RUSH Racing Series, its affiliates and RUSH Racing Series Sponsors the non-exclusive rights and authority to use my image and likeness, including my name, nickname, initials, picture, photograph, animation, persona, autograph/signature (including facsimiles thereof), voice, biographical information, and/or any and all other identifying characteristics, including the image of my vehicle, whether portrayed in still or action pictures, drawings, or other artistic renderings, in connection with my participation in RUSH Racing Series Events and for any and all uses or purposes that publicize and promote RUSH Racing Series or any of its affiliates in any way in any and all media or formats.

### **ENVIRONMENTAL WARNING:**

- A. **Any driver or crewmember** found to be altering, by means of contaminating the racing surface or pit area or racing entrances and/or staging or technical inspection areas or **ANY** part of the event grounds or properties and nearby driveways will be **disqualified**. The local authorities and/or agencies may be notified and the violator(s) and their information may be turned over to these authorities at that time.

- B. **No race cars or vehicles** including, but not limited to **race trailers**, or **support vehicles** or **trailers** will be allowed to carry or conceal, in marked, unmarked or using any form of misrepresentation of jugs or bottles or carrying devices of any type (with concerns to chemicals), for the purpose of altering, conditioning or changing a tire's baseline settings (from its original factory set baseline settings) will be allowed in or around the/any RUSH Series Event/s. All local authorities and applicable agencies may be called and the violators and their information will be turned over to these authorities at that time.

## **TECHNICAL RULES & REGULATIONS**

It is ultimately the obligation of each participant to ensure that their conduct and equipment complies with all of the applicable rules, as they may be amended from time to time; any amendments supersede any previous rules regarding any technical and/or aspect. An amendment is effective upon the date of the publication of the amendment regardless of when a competitor receives the actual notice.

**Any new components, including engine components, suspension components, body designs, frame designs and/or components of any type utilized in competition must be approved by RUSH Officials prior to being introduced into competition.**

### **Engines:**

- A. The General Motors (GM) Engine part number #88958602, 19258602, 19370602, 19418602, 19431602, 19432602 or 19433602 is the only engine permitted in all RUSH Stock Car events; RUSH reserves the right to amend this list of approved engine part numbers.
- B. All engines are to remain sealed from the factory. These engines are sealed at the intake manifold, cylinder heads, front cover and oil pan with special GM twist off bolts or cap seals. The original factory seals (bolt type or cap seal) must remain unaltered. Tampering, removal, or modifications of any type and/or broken factory seals, bolt type or cap seal, will not be permitted and will result in an immediate disqualification from the event (loss of points and money). The engine may be impounded immediately for further inspection.
- C. The exception to this will only be if a repair or rebuild is required. The repair/rebuild must be authorized by the RUSH Racing Series, at which time the engine may be repaired or possibly rebuilt per the guidelines set forth in the GM Technical Manual #88958668. Crate engines must not be altered, modified, or changed from factory specs, unless any such alteration, modification or change is approved by RUSH. RUSH Authorized Rebuilders will be notified of any such alteration, modification or change.
- D. Only RUSH seals will be accepted in the event of an engine rebuild/repair. *For any other sealing system, contact RUSH for approval.*
- E. Engines must be sealed in all of the above locations with either the "original" GM twist off bolt heads or cap seals, or RUSH seal tags, or a combination of the "original" GM twist off bolts or cap seals, and/or RUSH tags.
- F. The sealed engines must remain intact and not be tampered with; **any seals** that have been tampered with, removed, or modified, and/or broken will make the engine illegal and will result in an immediate disqualification from the event (loss of points and money). The engine may be impounded immediately for further inspection. Modifying any internal engine parts or changing the parts from stock as delivered sealed from the factory, other than those approved by RUSH, will result in disqualification for the night's event (loss of points and money), loss of all Series points to date in the division the infraction occurred in, suspension from all RUSH-sanctioned Series competition for 365 days, fined \$1,000, and an indefinite probation; penalties apply to both driver and car owner.
- G. The permitted GM factory sealed crate engines must not be altered, modified, or changed from the GM specifications set forth in the GM Technical Manual #88958668; no changes are allowed to the engine- intake manifold, heads, valve covers, front cover, oil pan, harmonic balancer, or any other part or parts on or in the engine. Any alteration, modification or change must be approved by RUSH. RUSH Authorized Rebuilders will be notified of any such alteration, modification or change.

<b>Valve Spring Specifications – New</b>		
<b>Description</b>		<b>88958602</b>
<b>Valve Spring P/N</b>		<b>10212811</b>
<b>Valve Spring P/N -set of 16</b>		<b>n/a</b>
<b>Diameter (+/- .010")</b>	<b>(A)</b>	<b>1.250"</b>
<b>Free Height (+/- .015")</b>	<b>(B)</b>	<b>2.021"</b>
<b>Installed Height (<i>Shimming of valve springs NOT permitted</i>)</b>	<b>(C)</b>	<b>1.70"</b>
<b>Pressure @ Installed Height (+/- 5 lbs)</b>	<b>(D)</b>	<b>80 lbs.</b>
<b>Open Height</b>	<b>(E)</b>	<b>1.270"</b>
<b>Open Pressure (+/- 10 lbs)</b>	<b>(F)</b>	<b>195 lbs</b>
<b>Coil Bind</b>	<b>(G)</b>	<b>1.20"</b>
<b>Wire Diameter</b>		<b>.177"</b>

H. RUSH GM Crate Engine rebuild/repairs must be authorized by RUSH Racing Series. RUSH GM Crate Engine rebuild/repair procedure works as follows:

- 1) RUSH authorized rebuild/repair center must complete the RUSH Racing Series Engine Seal Request, Engine Parts Release, and Engine Owner & Authorized Rebuild/Repair Facility Agreement forms must be completed in their entirety and e-mailed to RUSH Racing Series office at info@rushracingseries.com to receive permission from RUSH officials for engine to be rebuilt or repaired.
- 2) Only RUSH Racing Series authorized engine rebuild/repair facilities may be utilized. The list of RUSH authorized engine rebuild/repair facilities is available on the RUSH Stock Car website under the engine tab.
- 3) Based on the estimate and the detail of the rebuild/repair, RUSH Racing Series Officials will determine if the rebuild/repairs may be made or if a new engine must be purchased.
- 4) Upon completion of the rebuild/repair(s) the engine must be 'resealed' using RUSH seals before being released for competition.
- 5) All engine information regarding rebuild/repairs and/or engine introduction must be retained by RUSH Authorized Engine Repair Facility and turned into RUSH office at 4368 US 422, Pulaski, PA 16143 to be recorded into rebuilt/repaired engine database, which includes the engine owner, driver at time of rebuild/repair, engine serial number, repair, type of repair and/or what type of service was performed to any engine, along with RUSH seal numbers and specific location of seals.
- 6) The opportunity for an engine to be rebuilt/repaired will be at the sole discretion of RUSH Racing Series Directors upon reviewing RUSH authorized rebuild/repair center's RUSH "Seal Request and "Engine Parts Release" forms.
- 7) In the event a repair must be made to an engine scheduled to compete in consecutive RUSH-sanctioned events or if RUSH seals cannot be obtained in time for competition in a single event, engine owner and or competitor "must" have authorized RUSH engine repair facility of their choice contact RUSH Series Directors to receive permission and instructions on obtaining "approved" temporary seals in order for engine to compete. RUSH Competition Director can also install "approved" temporary seals in this situation. Temporary seals will "only" be permitted on repaired engines for events that are designated by RUSH Series Directors.

I. Engine's GM serial number and when applicable RUSH's build certification number must be clearly visible to Series' or track technical inspectors.

J. RUSH Racing Series Officials reserve the right to inspect, exchange and/or confiscate any GM Crate engine, or other specified engine component. In the event the engine or specified component is to be removed, it must be removed immediately by person(s) appointed by driver and/or car owner. Refusal to surrender an engine or other engine part for inspection, exchange or confiscation, will result in disqualification for the night's event (loss of points and money), loss of all Series points to date in the division the infraction occurred in, suspension from all RUSH-sanctioned Series competition for 365 days, fined \$1,000, and an indefinite probation; penalties apply to both driver and car owner.

- K. ANY VIOLATION OF THE ENGINE RULES AND/OR FACTORY SPECS INSIDE THE SEALING SYSTEM OF THE ENGINE WILL result in disqualification for the night's event (loss of points and money), loss of all Series points to date in the division the infraction occurred in, suspension from all RUSH-sanctioned Series competition for 365 days, fined \$1,000, and an indefinite probation; penalties apply to both driver and car owner.

After the suspension period, the driver and/or car owner can only compete in Series events with an engine equipped with original factory GM sealing bolts or cap seals, or RUSH seal tags.

For subsequent violations in regard to any illegal modification to any GM Performance Parts Crate Engine, an indefinite suspension may be issued.

- L. Any violation of the engine rules and/or factory specs outside the original GM twist off bolt heads or cap seals and/or permitted Series seal tags on the engine will result in the driver and car being disqualified from that event (loss of points and money). Multiple infractions outside the sealing system will result in the penalties stated in the "Multiple Infractions" section of the rules.
- M. The engine must be centered in the front of the chassis and placed in an upright position.
- N. Engine set back will be as follows; The maximum engine setback will be the center of the number one (1) spark plug hole, must align with the center of the top of the left side ball joint.

#### **Engine Protests/Selection:**

- A. Any RUSH-sanctioned race track and/or RUSH Series Director(s) are authorized to call for an engine inspection or tear down *at any time*. Inspection and tear down will be performed by RUSH Tech/Competition Director. Person(s) appointed by driver and/or car owner will remove engine immediately at race track and track/Series will impound engine until inspection day can be arranged for all parties involved. (See paragraph number five for procedures if selected car is to race in successive events.)
- B. The protest fee for a complete teardown of an engine that finishes the A main in the top five is \$2,000, and must be made by a driver/owner that finishes in the top five. \$300 of protest fee will go to Series or Track and the remaining \$1,700 will go to the winner of the protest.
- C. The protest fee for a partial teardown of an engine that finishes the A main in the top five is \$1,500, and must be made by a driver/owner that finishes in the top five. \$300 of protest fee will go to Series or Track and the remaining \$1,200 will go to the winner of the protest. A partial teardown will include the following: cam profiled along with the timing components, lifters, and cylinder heads verified.
- D. Protest and fee in cash must be made to a RUSH Tech Inspector, Race Director, or Track Tech Inspector within 15 minutes of the checkered flag of the feature. Protest cannot be withdrawn once it has been declared. Protested competitor cannot counter-protest in the same event.
- E. At any time an engine is protested and driver/car owner accepts protests and agrees to tear down, the engine being protested must be removed immediately by person(s) appointed by driver and/or car owner and impounded by Series/Track. Protested engine will be sealed by RUSH Official or person(s) appointed by RUSH to insure that it has not been tampered with, and to verify engine's identity. Any refusal to permit engine confiscation will result in disqualification for the night's event (loss of points and money), loss of all Series points to date in the division the infraction occurred in, suspension from all RUSH-sanctioned Series competition for 365 days, fined \$1,000, and an indefinite probation; penalties apply to both driver and car owner.
- F. *If the protested car wishes to race in successive RUSH-sanctioned events within 72 hours (three days) the following will apply ONLY at the discretion of RUSH:* RUSH Series Officials reserve the right and also grants the right to RUSH-sanctioned speedway tech officials to seal or otherwise identify the protested engine to allow the car to compete in successive events within 72 hours (three days). Further postponement of tear-down will be at the discretion of RUSH Directors/Officials. The driver and/or owner has the option whether to surrender the engine on the night it's protested or have it identified and retained for the successive races. However, if the driver chooses to compete with the engine after its selection for tear down, and that engine is found to be out of compliance with RUSH Technical/Engine rules, the driver will be disqualified from all races entered after the engine was protested, in addition to the race when engine was protested. RUSH *may* assess penalties for each race in which the selected

engine was used after its selection, if it is found to be illegal. If the engine is found to comply with all applicable rules, then driver/owner will be awarded all money and points earned for each event.

- G. At this time, the feature finish will be frozen until inspection is complete. In the event of a disqualification, finishing position, points and monies would be adjusted accordingly.
- H. Failure and/or refusal to tear down an engine and/or for your race car to be inspected by Series at any time will result in disqualification for the night's event (loss of points and money), loss of all Series points to date in the division the infraction occurred in, suspension from all RUSH-sanctioned Series competition for 365 days, fined \$1,000, and an indefinite probation; penalties apply to both driver and car owner.
- I. Inspection location will most likely be at RUSH office/garage located at 4368 Route 422, Pulaski, PA 16143. Although other inspection locations could be selected. There will be no dispute over RUSH Official's choice of location.
- J. Driver and/or car owner and one other representative of the team will be allowed in the tech area during the engine teardown. Only one representative from the team protesting the engine will be allowed in the tech area during the engine teardown. Additional attendees must be approved by RUSH pursuant to a written request. Protestor and protested driver and/or car owner along with the confiscated sealed engine and/or parts must be present at predetermined location. All parties must remain present during the entire teching procedure.
- K. Note: All removed original GM bolts or cap seals and RUSH Seals must be returned immediately to the RUSH Office.
- L. Engine infractions "within the bolts" will result in disqualification for the night's event (loss of points and money), loss of all Series points to date in the division the infraction occurred in, suspension from all RUSH-sanctioned Series competition for 365 days, fined \$1,000, and an indefinite probation; penalties apply to both driver and car owner.
- M. In the event that the series confiscates engine, for inspection, and said engine is found to be legal, and comply with the all the rules, the "Series" will provide a full GM gasket set, and the seals to reassemble engine at no charge to the authorized rebuilder and engine owner. If engine is protested by another racer for inspection, the engine owner is responsible for all expenses required for reassembly.

### **Carburetor / Air Cleaner**

- A. One unaltered 650 CFM Holley carburetor, HP 80541-1, 80541-2, 80541-3, 4777C or 80777 "highly" recommended and will be mandated 1/1/25.

*Chevrolet Performance 602 Circle Track Engines Perform best with a quality 650 carburetor*

- Carburetor must pass gauge (go/no-go) test, and meet Holley OEM measurements at all times, regardless of carburetor temperature.
- Booster height must remain stock OEM from Holley, no cutting or polishing.
- Carburetor must maintain the stock venturi and throttle bore dimensions.
  - a) The 4777C & the 80777 venturi will be 1-1/4" and the secondary must be 1-5/16". Throttle plate must be 1 11/16"
  - b) The HP 80541-1, 80541-2, and 80541-3 primary and secondary venturi must be 1 1/4". The throttle plate must be 1 11/16"
- Billet base/throttle plate "not" permitted.
- Billet center section "not" permitted.
- Metering blocks and bowls must be of stock appearing design, drilling high speed air correction jets is permitted.
- Drilling, tapping, and plugging of unused vacuum ports is permitted.
- Jets and power valves may be changed.
- Drilling holes in throttle plate for proper idling permitted.
- Welding throttle shaft to linkage arm permitted.
- Removal of choke plate and shaft on 4777C and 80777.

- B. As an option to the 650 CFM Holley carburetor part numbers listed above in letter A., one 750 CFM may be utilized; *only through 12/31/24.*
- C. Holley 26-342 or Holley 26-343 float bowl vent tube check valve is highly recommended.
- D. A single unaltered carburetor spacer plate with an unaltered square hole/opening including gasket with a maximum thickness of 1-1/8"-inch will be permitted. Tapering, machining and/or any other alteration to the spacer plate will not be permitted. Spacer may not protrude down into intake manifold.
- E. Pipe plugs must remain in manifold heat crossover port.
- F. Only a single conventional round type air cleaner housing will be permitted. There can be no metal attachment to the air cleaner/housing; ram-air, air box and /or heat shield type device will not be permitted. A maximum 2" non-tapered air cleaner spacer may be added.
- G. Air induction plastic carburetor insert and/or other devices that direct air into the air intake will not be permitted.
- H. Air diffusers will not be permitted.
- I. A minimum of two (2) throttle return springs and a metal toe loop mounted on the gas pedal will be required. The throttle return springs must be mounted in separate locations.
- J. Throttle linkage must be made of magnetic steel rod or tubing; no all thread.
- K. Only one mechanical fuel pump in the stock location will be permitted. Fuel must be delivered through the fuel system from the fuel cell to the mechanical fuel pump. Return line, pressure regulator of any type and/or other volume and/or pressure altering devices will not be permitted.

### **Ignition/Battery/Starter**

- A. Only stock OEM distributors will be permitted. Alterations and/or adjustments will not be permitted to distributor with the exception of the distributor advance curve may be locked. All other parts must remain stock.
- B. Trigger-type, crank trigger-type or magneto ignitions will not be permitted.
- C. The ignition must be mechanically driven in the stock OEM location.
- D. Only the stock OEM H.E.I. ignition coil and module will be permitted.
- E. One American Passenger Car sized battery with terminals on top or side and a maximum of 12 volts will be permitted. The battery voltage must not measure more than 14.3 volts. Step up transformer and/or any other device designed to increase voltage will not be permitted. No lithium batteries.
- F. The battery must be securely mounted between and above top of frame rails with positive terminal covered, *not permitted in driver's compartment.*
- G. One (1) mandatory battery disconnect switch must be installed on the rear deck, behind the driver seat, in a location that is easily accessible from the "outside" of the race car. The switch must be clearly labeled with off/on direction. The switch must be directly in-line with the NEGATIVE battery cable and be capable of completely disconnecting the NEGATIVE terminal of the battery from the race car. Negative or "ground" wiring connections must "not" be made anywhere from the battery negative terminal to the input side of the disconnect switch. An additional battery disconnect switch within the driver's reach may also be used.
- H. OEM stock firing order must be maintained for all engines. Standard GM Firing Order 18436572.
- I. All cars must have an ignition switch in the driver's compartment, which is clearly labeled ON/OFF and is easily accessible to the driver and/or safety crew. Engine must not run when in the OFF position.
- J. All cars must be self starting.

### **Lubrication/Oiling System/Oil Cooler**

- A. Only a single wet sump oil pump will be permitted. Dry sump oil systems will not be permitted.
- B. Only magnetic steel oil pans will be permitted.

- C. External type oil pumps and/or vacuum pumps will not be permitted.
- D. Accu Sumps will not be permitted.
- E. Engine evacuation systems by internal and/or external driven pumps or by connection between exhaust system and/or valve covers, intake manifold and/or oil pan will not be permitted.
- F. Oil coolers are not permitted.

### **Exhaust**

- A. Collector-type headers required. Must have four (4) tubes into one (1) collector of a consistent diameter. Schoenfeld part #145VCM2 or #145VCM2-3 highly recommended but not mandated.
- B. NO tri-y headers, merged headers, or square-tube headers allowed.
- C. Coatings not permitted, stainless not permitted.
- D. The complete exhaust system must remain under the car and exit to the rear of the car behind the driver; parallel to the racing surface. Exhaust "may" exit out the right side of car, but must exit in front of rear wheel and be flush with the body panel.
- E. Mufflers not required unless track mandates. If mandated, the only permitted muffler is the Schoenfeld #63030. Mufflers must be labeled clearly by the manufacturer.

### **Engine Cooling System/Radiator**

- A. Cast iron or aluminum water pumps permitted. No electric water pump.
- B. Radius tooth pulley systems will not be permitted.
- C. Only one (1) radiator will be permitted, plastic and/or carbon fiber radiators will not be permitted..
- D. The radiator must mount vertically in front of the engine. The radiator must remain in its stock OEM location between the frame rails
- E. A 2"-inch maximum air deflector in front of the radiator for engine cooling will be permitted.
- F. An auxiliary cooling tanks and/or overflow cans and/or canisters will not be permitted in the cockpit.
- G. All hose connections require double clamps.

### **Fan:**

- A. Engine must be equipped with a mechanical fan.
- B. No electric fan.
- C. The cooling fan for the radiator must be mounted in the stock OEM location on the front of the water pump. Fan mounted to the crankshaft will not be permitted.

### **Transmission/Driveline and Driveline Components**

- A. Aftermarket Transmission
  - 1) Bert, Brinn, Falcon (Winters), etc. permitted.
- B. No ball spline transmissions permitted.

C. Manual:

- 1) Any manual gear-type transmission must be OEM or OEM replacement case and have a working 7.25-inch minimum diameter, steel and/or aluminum, single or multi-disc clutch inside an explosion-proof STEEL bell housing. The bell housing must be a minimum 270 degrees around top of clutch/flywheel area.

D. Automatic:

- 1) Any automatic-type transmission must remain in an OEM or OEM replacement case, with a functioning OEM appearing pump.
- 2) The original OEM bellhousing must have an approved scatter shield constructed of minimum 0.125" inch by three (3) inch steel, 270 degrees around flex plate. Manual bump starts will be permitted.

E. All Types

- 1) The transmission must have a minimum of at least two forward gears and one reverse, plus neutral position.
- 2) With motor running and car in still position, the transmission must be able to engage the car in gear and the car must be able to move forward, then backward.
- 3) Only OEM production type transmissions will be permitted - two speed, three speed, four speed and automatic.
- 4) Five speed (or more) transmissions, "in and out" boxes, and/or quick change will not be permitted.
- 5) All functioning shift levers must be located in OEM position. The flywheel and/or flexplate must be bolted directly to the end of the crankshaft, and the pressure plate must be fastened and/or bolted directly to the flywheel/flex plate.
- 6) Only one (1) flywheel/flex plate will be permitted. All driveline components within the bell housing must rotate consistent with the RPM of the engine while the car is in any gear.

**Driveshaft**

- A. Only one (1) magnetic steel 2" diameter drive shaft connected from the transmission to the center section of the rear end will be permitted. Titanium and/or aluminum drive shafts and/or drive shaft yokes and/or driveline components will not be permitted. Driveshaft must be painted white and clearly labeled with car number on it.
- B. Only magnetic steel slip yokes on the rear end and transmission will be permitted.
- C. Two (2) 360 degree magnetic steel driveshaft loops, minimum 1/4" thick by 2" wide, must be mounted to the frame and wrap around the driveshaft. One must be mounted 6" behind the front universal joint with the second mounted 12" behind the front universal joint.

**Rear End**

- A. Stock passenger car and pickup OEM, and floater rear ends allowed (3/4 ton max.). One-inch inspection hole in housing required.
- B. Hubs and rotors MUST be OEM or aftermarket steel.
- C. No cambered rear ends or heavyweight axle tubes (maximum .250 wall, and housing bracing) permitted. Scalloped ring gears permitted.
- D. Torque differentiating differentials such as DPI Gold Track & Platinum Track will not be permitted.
- E. Locked rear ends only. Welding of gears in the rear end will be permitted.
- F. Non-adjustable upper trailing arm brackets only; must follow rear bushing rule and remain level from side to side.

G. Lower trailing arm brackets may be no lower than 2-3/4" from bottom of the axle tubes to center of bolt.

## **Fuel, Fuel Cells and Fuel System**

- A. All cars must have fuel cells that meet and/or exceed FIA/SFI 28.1/.2 and/or FT3 specifications and must be not be older than five (5) years from the date of manufacture. The fuel cell must not exceed a 24.5-US gallon capacity and must remain in a rectangle and/or square shape for measuring and calculating capacity. The fuel cell must be mounted securely in its container and centered between and above top of rear frame rails in the trunk area in a fixed location. Both sides and the rear of fuel cell must be protected.
- B. Fuel cell cap must be a threaded cap and/or ATL Part #TF751 1/4 Turn Bullet Cap, Schultz Racing Fuel Cell Parts #SFP-300 1/4 Turn Cap or similar 1/4 turn fuel cap.
- C. Pressure tanks on fuel systems will not be permitted. Auxiliary fuel tanks will not be permitted.
- D. The foam in the fuel cell must remain unaltered. A minimal cut in the foam will be permitted in the shape of a square or a rectangle. The cut may be no more than 1,000 square inches. The foam must retain the factory cut.
- E. The fuel cell must be enclosed completely in a rectangle and/or square container that is a minimum thickness of 20-gauge magnetic steel. An aluminum container may be used as an option and must be a minimum of .060"-inch in thickness. The entire container must be visible for ease of inspection.
- F. The fuel cell must be mounted with a minimum of two (2) .125" thick , minimum 2" wide steel straps. Straps must fully encircle the fuel cell. Fuel cells that are mounted in a square tubing frame will be permitted. A minimum of 7/16"-inch ASTM Grade 8 bolts must be used to mount fuel cell to frame.
- G. The bottom of the fuel cell container must be a minimum of 12" from the ground.
- H. Fuel cell protection plate: The fuel cell protection plate must be made of magnetic steel, minimum of 1/8" (.125) thickness - in addition to the existing container - and must be of equal size or more of the fuel cell container. Protection plate must be securely mounted to the framing on the bottom of the fuel cell container to prevent bowing and/or deflection. The 1/8" (.125) magnetic steel material must have an inspection hole drilled near the center of the piece to measure the thickness of the material.
- I. The fuel pick-up must be positioned on the top of the fuel cell and be constructed of steel. The fuel pick-up must have a check valve. **Pick-ups of vertical sides prohibited.**
- J. Fuel lines must not pass through driver compartment.
- K. For the purpose of inspection, the drive and/or crew must be prepared to drain fuel upon request for inspection and/or measurement.
- L. Fuel coolers of any type will not be permitted.
- M. No dry ice or any other cooling agents will be allowed on the motor during competition.
- N. Sunoco Race Fuels is the "Official" Racing Gasoline of the RUSH Stock Car division. Sunoco Standard 110 Octane, RUSH '91' and typical pump gas are the only fuels permitted for competition. Fuel with 15% (E15) Ethanol or greater will not be permitted. Methanol, nitrous oxide, nitro-methane, propylene oxide, MTBE, ETBE, butyl ethers, or any other performance enhancing chemical additives will not be permitted. **It is the racer's responsibility to know what he or she is putting in the fuel cell.**
- O. Series Officials may amend the fuel rule for any event, and will inform competitors.
- P. Series reserves the right to check fuel anytime. Three samples will be taken by RUSH or a RUSH appointed Track Official. Each sample will be identified as sample #1, sample #2, and sample #3. Sample #1 will be retained by Series and sent to an independent laboratory selected by RUSH; sample #2 will be given to selected fuel's driver/owner; and sample #3 will be retained by Series to be utilized as a tie-breaker in the event any issues may occur with samples #1 & #2. Sample(s) will be sent to an independent laboratory selected by RUSH. Fuel samples not conforming to RUSH Stock Car Series Fuel rule will be deemed illegal.
- Q. **PENALTIES FOR FUEL VIOLATIONS:** Disqualification from event (loss of points and money) in addition to the following penalties:
- First Offense: \$500 fine & 30-day suspension from any RUSH-sanctioned event plus all related lab testing costs.

- Second Offense: \$1,000 fine & 90-day suspension from any RUSH-sanctioned event plus all related lab testing costs.
- Third Offense: \$2,000 fine & 365-day suspension from any RUSH-sanctioned event plus all related lab testing costs.

### **Roll Cage:**

- A. A minimum 4-point competition roll cage is required; 6-point roll cage highly recommended. The roll cage must be constructed of magnetic steel tubing that is a minimum of 1 ½" in diameter, with a minimum tubing thickness of .095 (wall thickness). The roll cage must be located within the stock OEM parameters of the doors of the vehicle. Offset cages will NOT be permitted.
- B. A minimum of three (3) horizontal door bars are required on each door.
- C. Front and rear bars that pass through the firewall will be permitted, with one (1) kicker bar to the frame.
- D. A radiator protection bar will be permitted.
- E. No portion of the rear hoop may extend rearward past the lower trailing arm mount. The rear vertical roll bar hoop of the roll cage should be perpendicular to the frame and must not exceed a ten (10) degree variation from perpendicular in its vertical rise from the frame.
- F. The top halo must be no less than forty (40) inches across left to right and twenty nine (29) inches front to back, from outside to outside.
- G. Any bars that are utilized for the top portion of the roll cage, included, but not limited to the front and rear hoops, the top hoop, and the uprights, must extend a minimum of 2" -inch above the driver's helmet.
- H. A minimum of one cross bar in top halo of roll cage is required.
- I. The rear hoop must be a maximum of 12"-inches in from the bottom of the opera window and have an X- Brace consisting of one full horizontal bar and one full diagonal bar.

### **Chassis:**

- A. Metric G-body Monte Carlo, Cutlass, Grand Prix frame, 1978 or newer.
- B. All vehicles must maintain a minimum of 108" (inch) wheelbase.
- C. Altering of stock frame will not be permitted other than the following exceptions:
  - 1) Patching of holes and/or rusted) areas of the frame.
  - 2) Replacement of factory frames rails from front firewall to rear firewall. Replacement frames rails must be fabricated from magnetic steel, minimum of 2"-inches x 3" inches, and a minimum material thickness of .083"-inches.
  - 3) Relocation of front upper control arm mounts permitted. Only "cross shaft" style upper control arm mounts will be permitted, no "double shear" style mounts permitted.
  - 4) The rear frame may be replaced from the rear upper trailing arm mount towards the rear of the car. Rear upper spring mount may be modified to allow a spring "bucket" and weight jack bolt, and shock mount.
  - 5) Cross member may not be cut or altered except for the fuel pump or oil pan clearance.
- D. Bernheisel Street Stock Metric Chassis M Series "Full Perimeter", Part #788200, permitted, Available through Bernheisel Race Cars (717) 865-3119

### Driver side Intrusion plates:

- A. A minimum 1/8" (.125") thick **magnetic steel** intrusion plate on the driver's side door bars is mandated. Plate must cover the area from the top door bar to the rocker panel and from the rear down post to 6" in front of seat. Must be visible for inspection.
- B. Approved installation:
- 1) Welded plates- Individual plates between door bars are permitted but must be weld around the perimeter of each opening. Minimum area covered is 16 inches by 26 inches.
  - 2) A minimum of 16" x 26" plate bolted to fabricated 1/8" (.125") magnetic steel tabs, welded securely to the chassis, using a minimum of eight (8) x 3/8" Allen button head bolts. A minimum of three (3) fabricated 1/8" (.125") magnetic steel tabs and 3/8" Allen button head bolts required across top of the intrusion plate, a minimum of three (3) fabricated 1/8" (.125") magnetic steel tabs and 3/8" Allen button head bolts required across the bottom of the plate, and one (1) fabricated 1/8" (.125") magnetic steel tabs and 3/8" Allen button head bolt in each in the middle front and middle rear of intrusion plate.
  - 3) A minimum of 16" x 26" plate bolted to a minimum of six (6) approved-design door bar clamps using the included 12 x 1/2" Allen button head bolts per the manufacturer's specification. A minimum of three (3) approved-design door bar clamps and the included six (6) x 1/2" Allen button head bolts required across top of the intrusion plate and three (3) approved-design door bar clamps and included six (6) x 1/2" Allen button head bolts required across bottom of intrusion plate. Vendor and part number must be clearly labeled on part.
- C. Current approved-design door bar clamps – in order of submission:
- Bicknell Racing Products – Part Number: BRP 9547
  - Wehrs Machine & Racing Products – Part Number: WM397
  - Allstar Performance – Part Number: ALL4198
  - (No other manufacturer has submitted a design for approval at this time)

### Body: (See body diagrams at end of Rulebook for further body specifications)

- A. Body must maintain OEM 81-88 Chevy Monte Carlo fit and appearance and be centered on the chassis. Body must meet dimensions set forth in rule book per diagrams. Door, fender and quarter panel body lines and seams must be present and meet OEM standards. No offset bodies or raised quarter panels.
- B. Steel or aluminum doors, quarter panels, fenders, hood and trunk. No fiberglass or composite body panels permitted with the exception of the Performance Bodies 2-Piece Roof Kit, Part #PRPF-1015-81W, which is highly recommended.
- C. Performance Racing Bodies '88 Monte Carlo nose Part #MD3021-410[X], tail Part#PER21[X]100 are mandated.
- D. See pages 32-36 for approved Performance Bodies '88 Monte Carlo Aftermarket Body Part #s. These body *panels are available throughout the region via various distributors such as Precise Racing Products, Close Racing Products, Wedge Motorsports*
- 1) Manufactured Performance Bodies panels and templates made from .040" aluminum or 22-gauge white steel.
- E. ALL cars must have stock appearing roof. NO flat, late model or open wheel modified style roofs allowed. All roofs must have roof supports both front and rear and maintain stock appearance; Performance Racing Bodies A-pillars Part #F1015-81W-A-L (left) & Part #F1015-81-W-A-R (right) are highly recommended."
- F. Cars must compete with a roof unless the event is designated as a "topless" event and previously approved by RUSH Officials; **however, approved roof plates will be permitted only in this case.** Roof, roof supports, and window side panels must be removed, all other body rules remain in effect.

- G. ALL cars must have a stock appearing hood and trunk; hood must be removable and held in place by four hood pins, trunk may be removable or hinged/pinned must be able to open for inspection purposes.
- H. Deck Height: 40", no tolerance, measured at center of car, from top of tail at rear edge of deck to ground.
- I. Deck Width: 64" maximum.
- J. Body must not be any wider (from side to side) than 68", measured at driver's compartment (see body diagram B).
- K. Rear of car must not exceed 64" wide, measured at top of rear deck (see body diagram A).
- L. Both sides of the body must taper the same on each side. No single side taper or "late model" type body taper.
- M. The side window opening(s) must be a minimum of 13" from the top of the door to the bottom of the roof.
- N. Performance Bodies aftermarket plastic nose piece part #MD3021-410[X] mandated.
- Approved nosepiece must be installed per the manufacturer's instructions, meet the maximum/minimum dimensions, maintain manufacturers appearance and not be altered.
  - All nose pieces must be made of molded material and mounted in the center of the car; it must be mounted in a manner that does not alter its original shape.
  - The nose piece can extend a maximum distance of 40" from the center of the front spindle nut to the farthest point extending forward.
- O. Front of car must be enclosed. NO floppers or fender skirts on front end like a late model. All fender enclosures must remain tight with body lines and be riveted to fenders, tucked in tight with body lines. Nose pieces should be mounted high and tight like a streetcar. No raked mounting of nose. Maximum of 3" fall from firewall to leading top edge of nose piece. No wedge or late model style nose pieces allowed.
- P. Performance Bodies aftermarket tail piece part #PER21[X]10 mandated. Tail of car must be completely enclosed. NO holes in tail pieces.
- Approved tail piece must be installed per the manufacturer's instructions, meet the maximum/minimum dimensions, maintain manufacturers appearance and not be altered.
  - All tail pieces must be made of molded material and mounted in the center of the car; it must be mounted in a manner that does not alter its original shape.
  - The maximum distance from the center of the rear axle flange to the rear of the tail piece is 49"
  - The maximum distance from the center of the rear axle flange diagonally to the top of the tail piece is 47"
- Q. All body panels must be solid. No holes, slots, or air gaps permitted. NACA ducts or NACA style ducts are not permitted. The exception will be; a maximum of six holes approximately 2" in diameter will be permitted in the grill area of the mandated Monte Carlo Nose for engine cooling purposes. See page #33 for reference to grill location.
- R. No raised gurney lips or fins will be permitted anywhere along the entire length of the car; the body line must be an even line from front to rear.
- S. Wings, tunneling and/or any type of air deflection device will not be allowed underneath the body or chassis, along frame, or around the fuel cell area.
- T. Panels of any type under the rear deck running from front to rear of the car will not be permitted.
- U. "Belly pans" or any other type of enclosure on the bottom of the car will not be permitted; a skid plate to protect oil pan is permitted, maximum 1/8" ski plate.
- V. Maximum 1" x 1" standard steel tubing side rub rails permitted; must extend from the fender well to the rear quarter panel and must mount through the body to the structure of the chassis. Lexan rub rails permitted; may be fastened to the body only.
- W. Exposed bars, tubing, and/or bracing past the outside of the bodyline of the car, other than rub rails, will NOT be permitted.

- X. No sharp edges permitted on bumpers, rub rails, bolts, etc.
- Y. Front, rear, and/or side spoilers of any type are not permitted.
- Z. All non-approved bodies or any section(s) of the body may be assessed a "minimum" fifty pound (50 lb.) weight penalty at the discretion of Competition Director or not permitted to race.

**Driver Compartment:**

- A. Driver's seat must remain on the left side of the driveline.
- B. The front windshield opening must be covered with ½" x ½"-inch and/or 1" x ½"-inch wire mesh. It is also mandatory that three (3) support bars fabricated from magnetic steel tubing, a minimum of 1"-inch diameter and .095" wall thickness be spaced equally in front of the driver and welded to the top roll cage bar and the dash bar of the roll cage in a vertical manner.
- C. Full engine firewall, rear firewalls, and floor pan are required; constructed of heavy gauge aluminum, .080" minimum thickness.
- D. The firewalls (front and rear) and floor pan must be sealed and complete, on both the driver's side and passenger side of vehicle, frame rail to frame rail. The floor pan may be cut for the mounting of the roll cage only, and can be no higher or lower than the frame rails.
- E. The firewalls must be at a 90-degree angle from the floor pan.
- F. Entire front firewall can be no more than 12" from the rear edge of the engine block, measure horizontally. No part of the of firewalls and pan may be offset.
- G. The entirety of the firewalls and floor pan must be on the same plain, with the exception of the required driveshaft tunnel. Maximum driveshaft tunnel height is 8".
- H. Open holes in the firewalls and floor pan will not be permitted. Repair of firewalls and floor pan, if needed, must be made with the minimum thickness of the magnetic material that was originally utilized.
- I. The front of the rear firewall must maintain the same height as the top of the front of the dashboard.
- J. The maximum length of the dashboard from the front firewall to the edge of the dashboard panel will be 24"-inches. Dashboard must be flat, level, and complete from left to right, front to back except for cowl in front of the driver. Dashboard cannot be lower in height than the top of the door.
- K. Cockpit Syle Interior Option:
  - Interior deck from the hood edge of the dash to behind the driver's seat must be flat from side to side, front to rear.
  - The interior from behind the driver's seat to front edge of the trunk can rise to follow the body lines, but must remain flat from side to side.
  - The rake of the interior deck from behind the driver's seat to the front edge of the trunk must be a straight flat line.
  - Interior decking must be made of aluminum.
- L. The trunk floor area may be cut to allow for the mounting of the fuel cell.
- M. A maximum seven (7) inch visor/sun shield may be added to the top of the windshield opening. The window openings, front and/or rear, driver and/or passenger side must retain their stock OEM dimensions.
- N. All glass, plastics, chrome, airbags, and mirrors must be removed. Mirrors of any type will not be permitted.
- O. Any edge and/or sheet metal end in and around the driver's compartment must be protected with trim and/or beading and rounded. Sharp and protruding edges will not be permitted.

- P. Support bars that block the right window from the driver exiting the cockpit will not be permitted.
- Q. A substantial rock guard with a minimum of three (3) window bars must be mounted in "front" of the driver. The rock guard must be made from wire or screen. Windshield screens must be a minimum of .090 inches and must be securely fastened.
- R. All cars must have an ignition switch in the driver's compartment, which is clearly labeled ON/OFF and is easily accessible to the driver and/or safety crew. Engine must not run when in the OFF position.
- S. SFI Spec 45.1 roll cage padding is mandated anywhere the driver's helmet may contact the roll cage while in the driving position. Other cockpit padding, knee, and steering pads, etc. recommended.
- T. Window nets certified to SFI Spec 27.1 or safety nets certified to SFI Spec 37.1 are highly recommended and shall be installed and used in accordance with manufacturer's instructions.

### **Gauges and Dash Modules:**

- A. Gauges to monitor engine conditions are permitted but will be limited to the following;
  - Oil pressure
  - Oil temperature
  - Engine coolant pressure
  - Engine coolant temperature
  - Fuel pressure
  - Battery voltage
  - Engine RPM
- B. All electronic gauges whether analog or digital, except tachometers, will only be permitted to have one (1) input from the respective gauge sensor. Outputs from the gauges will not be permitted. Tachometers will be permitted to record engine RPM for recall and playback.
- C. When an electronic dash module is used in lieu of individual gages, only the inputs as described above for individual gauges will be permitted. All other input channels must be disabled and blocked off from usage. Only engine RPM may be recorded. Wiring to the electronic dash module must be accessible and removable for ease of inspection.
- D. All additional wiring harnesses related to electronic dash modules or any other type of data acquisition must be completely removed from the race vehicle during an event.

### **Suspension**

- A. All suspension components must remain stock in their OEM mounting locations for the mandated chassis, with the exception of the FRONT upper control arm mount.
- B. Upper cross shaft style A-Frames are required. Upper A-frame mount may be moved or replaced with aftermarket steel non-adjustable, non-slotted mount matching upper A-frame bolt on cross shaft style design. Stock Style A-Frames may be reinforced along the edges by welding round stock.
- C. Lower A-frames must be stock/stamped OEM and not be altered or moved from their stock mounting location and must match chassis No shortening or lengthening of lower control arms. Homemade lower control arms will not be permitted. Tubular lower a-frames of any kind will not be permitted.
- D. Front shock location may be moved and may go through center of aftermarket upper A-frame; maximum one 3" wide opening on side of spring tower to provide shock clearance. Non-adjustable single hole only shock mount to accommodate RUSH Bilstein sealed/spec shocks with ½" bearing ends.
- E. Both rear shocks must be located behind the axle in stock location with shock mounts altered to accommodate RUSH Bilstein sealed/spec shocks with ½" bearing ends. Rear spring bucket may be modified to allow for shock mounting. A cross bar may be utilized for upper shock mounts but the shock must remain in the OEM location

- F. Aftermarket 3-piece metric spindles will be permitted.(Performance Racing Products Part #PRP34501 or Speedway Part #910345010) Pinto spindles of any type are NOT allowed.
- G. Pitman and idler arms must be stock or OEM replacement stock.
- H. Heim joints permitted as an OUTER tie rod replacement only; inner tie rods must remain stock or OEM replacement stock.
- I. Stock OEM or aftermarket center link will be permitted. Aftermarket center link must be a direct replacement for stock center link.
- J. Ball joint must remain centered in the stock location.
- K. Bolt-in and screw in ball joints will be permitted. Adjustable and/or truck type ball joints will not be permitted. Cutting and/or alterations to the frame will not be permitted to accept any other type or style of ball joint.
- L. The lower rear trailing arms must remain in their stock OEM length, from the original OEM application and measurement system (English or Metric) and must remain specific to the mandated chassis/frame and must be the same length on each side. Tubular arms will be permitted but MUST maintain stock OEM length factory length. Heim ends are NOT allowed.
  - 1) Length:
    - a) Metric - 19.5 inches
  - 2) The lower rear trailing arm mounts must be mounted in the stock location on the frame.
    - a) Mounted 2 3/4" maximum from bottom of rear end housing to the center of the control arm bolt.
    - b) No additional holes in frame allowed. Stock mount holes only. Frame mounts MUST remain unaltered and in stock location.
    - c) Slots in the frame or rear-end mounts will NOT be permitted.
- M. The upper rear trailing arms may be altered (shortened and/or lengthened) to obtain the correct pinion angle.
  - 1) Upper control mounts maximum of 3" from center of top of rear end housing to center of control arm bolt or on a 9" Ford housing 7 3/4" from seam of center of axle tube to center of mounting bolts.
  - 2) Upper rear trailing arm rear end mounts must be level side to side, non-adjustable, and consist of one hole on each side.
- N. Aftermarket bushings will be permitted, but the arm must not be altered in any manner. Adjustable/and or rod ends (heims) will not be permitted.
- O. No panhard bar or z-bars of any type; No underslung suspension.
- P. Suspension components that are adjustable within driver compartment of any-type will not be permitted, aside from brake bias adjusters.

## **Steering**

- A. Conventional steering boxes only and must remain in OEM location as manufactured for the make, model and year. No rack and pinion steering.
- B. Collapsible steering shaft mandated.
- C. All cars must be equipped with a quick-release-type steering wheel that is a full circle.
- D. Steering quickening devices are permitted.

E. Electronic steering or electronic steering components will not be permitted.

### **Springs**

- A. The springs must be of the OEM stock-type. Five (5") or 5-1/2" diameter coil spring mandatory. Springs must be mounted vertical on top of rear.
- B. Springs must be maximum 13" free height and must maintain same height on both the left and right side of car.
- C. Aftermarket coil springs will be permitted. Non progressive springs only. Spring rubbers permitted, one per corner.
- D. Springs must remain vertical in the OEM location on top of the rear tube. No angled spring mounts of ANY kind allowed.
- E. Coils must be mounted in stock location on top of the rear tube.
- F. Coil-over applications of any type not permitted.

### **Shock Absorbers**

- A. Shock absorbers are restricted to the following six part numbers manufactured by Bilstein on a proprietary basis for the RUSH Stock Series:
  - RUSH RF 9-3
  - RUSH RF 7-3
  - RUSH 4-3
  - RUSH LRF 2.5-2.5, CR USA LRF 2.5-2.5 (These two shock part numbers are the identical shock and valving except for the part number.)
  - RUSH RR 3.5-1.5, CR USA RR 3.5-1.5 (These two shock part numbers are the identical shock and valving except for the part number.)
  - RUSH LRB 3-6, CR USA LRB 3-6 (These two shock part numbers are the identical shock and valving except for the part number.)
- B. Only one (1) shock per wheel will be permitted. Rear shocks must remain behind the rear end housing.
- C. These sealed shocks do not have an external gas port; they are factory sealed. No attempt may be made to disassemble the shocks, or may shocks be altered in any way.
- D. Gas pressure may not be altered by drilling, addition of a visible gas port, a hidden gas port, or by any other means.
- E. These shocks are machine sealed via an external crimp in their sturdy steel body. Valving may not be altered by any means, and external inspection of the shock may not show that an attempt has been made to defeat the seal.
- F. Shock shafts may not be strategically bent to a pre-determined profile for the purpose of changing the shock's compression or rebound performance.
- G. Shock covers permitted, but must be removed for all technical inspections.
- H. Suspension limiters must be solid chain only. No shock absorbing devices of any kind allowed on suspension limiters. The purpose of these limiters is to prevent spring rotation/loss only!

- I. Weight jacks permitted
- J. Hydraulic ratchet and/or electric weight jacks are not permitted.
- K. Series or Track Officials reserve the right to confiscate any shock from the car of any competitor for purposes of dyno testing. If the resulting graph of that specific shock fits Bilstein's valving and gas pre-load templates the shock will be returned to the owner. If any anomaly appears regarding external tampering evidence, or failure to fit the valving and gas-preload templates, the shock will be shipped to Bilstein and cut apart for examination of piston, valve stack, oil, and the body will be examined for drilled and hidden gas ports. If an alteration is detected Bilstein will photo document the valve stack, oil, or the alteration in the body to RUSH Series officials.

If, upon dyno testing and inspection, it is determined that the gas pressure, seals, piston, oil, shock tube, rod, or valving has been altered in any way, the shock absorber will be determined illegal and RUSH published penalties will apply.

RUSH Racing Series Officials reserve the right to technically inspect, exchange and/or confiscate any specified Bilstein sealed shock at any time.

**PENALTIES FOR SHOCK VIOLATIONS:** Disqualification from event (loss of points and money) in addition to the following penalties:

- First Offense: \$500 fine & 30-day suspension from any RUSH-sanctioned event plus all related testing costs.
- Second Offense: \$1,000 fine & 90-day suspension from any RUSH-sanctioned event plus all related testing costs.
- Third Offense: \$2,000 fine & 365-day suspension from any RUSH-sanctioned event plus all related testing costs.

## Weight

- A. 2,800 lbs. with driver
- B. The scales designated for the event will be considered the official scales for the event.
- C. Any car that is found light at the scales following qualifying/time trials will lose its time and start from the rear of a heat. Any car that is light at the scales following a heat race, B main/consy, or feature will be disqualified from the event.
- D. Additional weight(s) must be securely attached to the frame inside the frame rails and/or behind the body on the frame; frame is defined as the steel welded structure only. Any part that moves or is not a fixed component to the steel frame structure may not be utilized for any additional weight attachments.
- E. Weights up to 50 lbs. must be positively fastened by two (2) 1/2-inch diameter, minimum grade 5 bolts with a minimum of two (2) weight clamps. Threaded rods will not be permitted. Weight must be painted white with car number displayed. Any car that loses any weight/ballast during an event may be subject to a penalty.
- F. No weights attached to the front or rear bumper, rear end or axle tubes or in the driver's compartment.
- G. Pellet-type and/or liquid-type weight/ballast will not be permitted.
- H. No driver-operated weight adjustment devices.

## Wheels

- A. Only one-piece 8" steel production racing wheels will be permitted.
- B. All four (4) wheels must have a minimum five (5) studs and lugs nuts. The stud threads must go past the full thickness of the wheel nut on all four corners of the car.

- C. External steel beadlocks permitted; steel bolts must be utilized. Beadlock may not make wheel any narrower than 8" or wider than 8.75". Aluminum beadlock rings permitted.
- D. Wheel center may not be altered.
- E. No wide 5 wheels or adapters
- F. Weights of any kind, added to wheels other than conventional balancing are not permitted.
- G. Wheel spacers must be aluminum.
- H. Bleeder valves of any kind will not be permitted.
- I. Wheel covers permitted on the right side only. Only steel wheel cover fasteners permitted. It is highly recommended that wheel covers have a minimum of 5 mounting points. However, 5 and 3 mounting point wheel covers will be allowed for competition under the following conditions: Wheel covers having a minimum of 5 attachment points may continue to use steel dzus fasteners. Dzus fasteners must be made of steel only. Wheel covers having only 3 attachment points must be bolted-on at all 3 points utilizing a minimum 1/4" or 5/16", magnetic steel hex head bolt and an approved fastening (nut assembly) system. No adjustable mounting rings allowed.

Approved fastening (nut assembly) systems:

- 1) Precise Racing Products Part # WCBK
- 2) Keyser Manufacturing Part #100 7-101.
- 3) Wehrs Manufacturing Part # WM377A-312 Aluminum 5/16" / WM377S-312 Steel 5/16"
- 4) Triple X Chassis Part # SC-WH-7810(for a 1" spring) / SC-WH-7820 (for a 1 3/8" spring)
- 5) Smith Precision Products Part # MC-516-18

Optional fastening systems that are equal or superior to the above-approved system will be readily approved at the sole discretion of Technical Officials.

- 1) Foam inserts are also permitted.
- 2) A minimum of five (5) lug nuts on the rear wheels will be required. A minimum of five (5) lug nuts will be required on the front wheels. Knock off hubs of any type on any wheel will not be permitted.

## Tires

- A. Only Hoosier Racing Tires will be permitted in any RUSH-sanctioned events. Hoosier (the tire manufacturer) will mark/stamp/brand all legal tires with specified compound and/or other specific RUSH designations as listed below;

### Tire Size and Compound Designation:

- Hoosier 26.5/8.0-15 or 27.5/8.0-15 Medium 100's, Medium or Hard.
- RUSH Series Officials may amend the tire rule for any event if track conditions and/or unforeseen circumstances warrant, and will inform competitors.

- B. **WARNING:** RUSH and Hoosier Racing Tires strictly forbids any chemical alteration of the tire carcass and/or tread compound such as tire soaking or use of tread "softener". RUSH and Hoosier Tire strictly forbids the physical defacement (removal, altering, or covering) of tire sidewall markings in any manner. Failure to comply with this warning could result in premature or catastrophic tire failure and may result in serious injury or death.
- C. RUSH or RUSH appointed Track Officials may take physical samples to insure that no competitor has employed any chemicals to alter the performance of his or her tires at any time during the event.

Three samples will be taken per selected tire; samples will be taken by RUSH or RUSH appointed Track Official. Each sample from selected tire will be identified as sample #1, sample #2, and sample #3. Sample #1 will be retained by Series and sent to an independent laboratory selected by RUSH; sample #2 will be given to selected tire's driver/owner; and sample #3 will be retained by Series to be utilized as a tie-breaker in the event any issues may occur with samples #1 & #2. Sample(s) will be sent to an independent laboratory selected by RUSH.

Tire samples not conforming to manufacturer's submitted factory benchmark will be deemed illegal. Results are the sole property of RUSH. Driver and/or car owner will be notified of results, and in writing if tire sample(s) do not match the factory benchmark.

- D. It is the driver's responsibility to know what is on their race car at all times. Any used wheels or tires that may be suspect by the driver should not be used. The driver, owner and/or appointed team representative may be in the tech area to view what is being tested.
- E. Any tire thought to be physically defaced or altered will be confiscated. While tire is in question, all money and points for that driver will be held until a ruling is made final. Any tire deemed to have been physically defaced or altered will be result in disqualification from the event (loss of money and points) along with the following:

**PENALTIES FOR ILLEGAL TIRES:**

- 1) First Offense: \$500 fine & 30-day suspension from all RUSH-sanctioned events plus all related lab testing costs.
  - 2) Second Offense: \$1,000 fine & 90-day suspension from all RUSH-sanctioned events plus all related lab testing costs.
  - 3) Third Offense: \$2,000 fine & 365-day suspension from all RUSH-sanctioned events plus all related lab testing costs.
  - 4) Failure to allow any tire(s) to be confiscated will result in additional \$500 per tire fine in addition to any other fines and penalties. All decisions are final.
- E. Removable duct tape, provided it does not deface the tire, to cover the D-Number will be permitted.
  - F. Heating of the tires by torch, blanket, heating device(s), exhaust system and/or any other method will not be permitted.
  - G. Inner liners of any type will not be permitted.

**Brakes**

- A. All cars must have four (4) wheel hydraulic brakes in good working condition.
- B. Carbon fiber, carbon, titanium, ceramic, aluminum pads and/or rotors will not be permitted.
- C. Only a single brake bias adjustment permitted in the cockpit.
- D. Manual brake shut offs will not be permitted, with the exception of the right front brake.
- E. Only stock/STEEL type OEM brakes will be permitted. Disc brake(s) will be permitted on the rear brake(s) provided that the rear brake caliper(s) match the front brake calipers. Alterations to the rear brake rotors, to fit the rotor to the rear only, will be permitted. Steel or aluminum brake lines only; no plastic brake lines.
- F. Aftermarket pedal assembly permitted
- G. No Scalloped rotors of any kind on any corner.

**Exotic Materials:**

- A. All exotic materials are illegal, which includes titanium, magnesium, tungsten and/or carbon fiber. EXCEPTION: carbon fiber seats provided they meet the 39.2 specifications & carbon fiber fan blades.

### **Traction Control/Radio/Transmission Devices:**

- A. All traction control devices are strictly prohibited during any form or portion of a RUSH Series sanctioned event, race or practice/test session.
- B. All traction control devices, whether electronically controlled in the ignition system, wheel sensors or any means of measuring ground speed to control wheel spin, are strictly prohibited. All devices not mentioned in the above that are found to control wheel spin, timing or fuel delivery control will be considered strictly prohibited.
- C. At NO time will there be any type of ping control devices, remote devices that modify RPM and/or timing, automated throttle controls, timing controls, or any modifications to the ignition control boxes, distributors, or any other part of the Ignition System. This includes any add on component or components inside or outside the cockpit of any competitor's race car. There shall be NO driver controlled wheel spin, timing or fuel delivery control devices in the cockpit area of any race car. Remote control components utilized to affect and/or control wheel spin, timing or fuel will not be permitted.
- D. Adjustable restrictor plates will not be permitted.
- E. Radios and/or devices transmitting voice and/or data will not be permitted.
- F. Data acquisition systems will not be permitted.
- G. A competitor found with any of the devices mentioned under Traction Control/Radio/Transmission Devices, #1-6, will be disqualified from the event (loss of points and monies), forfeit the device permanently and the following:
  - 1) First Offense: \$500 fine & 30-day suspension from any RUSH-sanctioned event plus any testing costs, if required
  - 2) Second Offense: \$1,000 fine & 90-day suspension from any RUSH-sanctioned event plus any testing costs, if required
  - 3) Third Offense: \$2,000 fine & 365-day suspension from any RUSH-sanctioned event plus any testing costs, if required
- H. A competitor refusing to relinquish any of the above mentioned will result in disqualification from the event (loss of points and monies) and "refusal of tech" penalties.
- I. GPS and/or any other type of electronic tracking and/or locating/positioning device will not be permitted for any reason. If found, driver and car will be disqualified for the night (loss of points and monies), and will forfeit device permanently.
- J. GoPro and/or similar camera devices are permitted providing they do not interface with the car, electronic or otherwise, and do not transmit any signals. Cameras not meeting specifications, will result in driver and car being disqualified for the night (loss of points and monies), and will forfeit device permanently.
- K. No cameras and/or video recorders and/or photographic recording equipment may be mounted below the deck. If found, driver and car will be disqualified for the night (loss of points and monies), and will forfeit device permanently. Note: RUSH reserves the right to mount recording equipment below deck, with driver's permission. near rear bumper facing outward towards oncoming competitors for promotional purposes.
- L. Antennas will not be permitted in and/or attached to the race vehicle or carried by the driver. If found, driver and car will be disqualified for the night (loss of points and monies), and will forfeit antenna permanently.

## **PERSONAL SAFETY EQUIPMENT:**

### **General**

- A. Each competitor is solely responsible of for the effectiveness and proper installation, per the manufacturer's specifications, of personal safety equipment and determining it to be adequate for competition at every event. Each competitor is expected to investigate and educate themselves for continuing improvement regarding their own personal safety equipment.
- B. RUSH Rules regarding safety equipment are the minimum and you will not be permitted to compete if your safety equipment does not meet the RUSH rules. Many tracks and or states require additional safety equipment not mandated by RUSH. Be sure to familiarize yourself with the requirements of each track. RUSH-sanctioned tracks and/or any track hosting a RUSH event will be required to enforce the RUSH safety rules completely without exception.

### **Protective Clothing**

- A. All drivers will be required to wear a fire resistant driving uniform meeting minimum of the SFI 3.2A/5 specification and display a valid SFI 3.2A/5 label on the outside of the uniform. Uniform must be worn at all times when driver is on the track including engine starts, practice, and competition.
- B. Driver's gloves and shoes must meet or exceed the SFI 3.3 specification and have a legible and valid SFI 3.3 label. Drivers must wear gloves and shoes at all times when they are on track including practice and competition.
- C. All drivers should wear fire resistant accessories including but not limited to; head sock, under garments, and socks at all times when they are on the track.

### **Full Containment Seats**

- A. Seats must be "Full Containment" style constructed of aluminum to the general design specifications of current industry standards, (SFI 39.2 highly recommended). Design shall include comprehensive head surround, shoulder and torso support system, energy impact foam, and removable head foam. Seats must be used as supplied and installed following instructions provided by the seat manufacturer. Consult with your seat manufacturer for questions and recommendations regarding your seat safety system.
- B. Seats manufactured using carbon fiber or composite materials must meet SFI 39.2 specifications.
- C. Up-fitting an existing seat with bolt-on kits will be permitted with a seat manufacturer-produced kit and an acceptable base seat approved by the seat manufacturer. Components must be include comprehensive head surround, shoulder and torso support system, and energy impact foam. Consult with your seat manufacturer for recommendations regarding your current seat.
- D. If the left head surround is 7"-inches or less when measured from the back of the headrest, then a left side head net meeting the SFI 37.1 must be installed with a quick release latch. A minimum left side head surround of 4"-inches is required.

### **Seat Belts/Restraint System**

- A. Each car will be equipped with minimum of an SFI 16.1 or SFI 16.5 approved restraint system. Restraint system will be eligible for use in competition until the expiration date or for two years from the date of manufacturer.
- B. Seat belt restraint systems shall be installed and used in accordance with manufacturer's instructions.
- C. In any type of manufacturer's installation the fasteners must be magnetic steel unless using type of mount in which the seat belt wraps around the roll cage. A seven-point harness is recommended.

- D. Seat belt material should not be permitted to come in contact with any sharp or metal edge, including when the material passes through the seat.
- E. Rolled and/or deburred and/or flanged edges or anywhere seat belt webbing passes through and may come in contact with abrasive edges are recommended.
- F. Arm restraints are recommended and must be connected and used as instructed by the manufacturer.

### **Helmets/Head & Neck Restraints**

- A. All drivers must wear a full-face helmet with a minimum safety rating of FIA 8859-2015, FIA 8860-2018, Snell SA2025, Snell SA2020, Snell EA2016, Snell SA2015.
- B. At all times during an event including practice, qualifying and competition drivers **MUST** wear an SFI-approved head and neck restraint device/system that is properly mounted and connected per the manufacturer's instructions.
- C. The head and neck restraint must be SFI 38.1 approved and display a legible and valid SFI 38.1 label. Per SFI 38.1, head and neck devices should be re-certified every 5 years; this will become mandatory in the near future.

### **Fire Suppression**

- 1. It is **HIGHLY** recommended that cars utilize a thermally deployed automatic fire suppression system per the following specifications; they will be mandated in the future.
  - The fire suppression system will consist of a DOT-approved cylinder manufactured from aluminum or steel with a capacity of 10 lbs. of fire extinguishing agent, steel or steel reinforced lines, and has a minimum of two (2) thermally activated discharge nozzles.
  - All systems must meet or exceed SFI 17.1 specifications. SFI Label must not be expired and easily accessible for tech officials to read.
  - Systems must be fully charged with 10 lbs. of DuPont FE-36, 3M NOVEC 1230, FireBull, or 4Fire and display a legible and valid SFI and manufacturer label depicting fire extinguishing agent, capacity, and certification date. Cylinders that are beyond useful certification date must be inspected, serviced, and re-labeled by the manufacturer.
  - Cylinders must be mounted forward of the fuel cell. Cylinders must be securely mounted to the frame/roll cage assembly. The certification label must be unobstructed and easily accessible for inspection when the mounting is complete.
  - Two (2) thermally activated nozzles must be used. One (1) nozzle must be located directly above the fuel cell in the fuel cell area and the second nozzle located in the driver cockpit area. An optional engine bay nozzle may be added.
  - An optional manual override cable may be added.

### **Roll Bar Padding**

- A. SFI Spec 45.1 roll cage padding is mandated anywhere the driver's helmet may contact the roll cage while in the driving position. Other cockpit padding, knee, and steering pads, etc. recommended.

### **Other General Safety Items**

- A. Sharp and/or protruding edges in and around the cockpit will not be permitted.
- B. All cars must have an ignition switch in the driver's compartment, which is clearly labeled ON/OFF and is easily accessible to the driver and/or safety crew. Engine must not run when in the OFF position.
- C. A fire extinguisher in the rear of team's transporter is highly recommended. Fire extinguisher should be a minimum of 20lbs and is recommended to be FFF type chemical and/or Dupont FE-36 and/or equivalent.

### **Other**

- A. All cars may be subject to technical inspection at any time. Any driver fails to cooperate and/or allow an inspection of his car at any time will be subject to disqualification and/or fine and/or suspension and/or any other action deemed appropriate by the RUSH Series Officials.
- B. All fuel lines, power steering lines and/or fittings running through the driver's compartment must be made from an approved braided type line. Plastic and/or glass fuel filters will not be permitted.
- C. SFI-approved and labeled seat, roll bar, knee and steering pads and/or padding is recommended.

### **Driver Radios/Transponders:**

- A. All drivers are required to have a one-way radio to be utilized for communication from Track and/or Series Officials. The one-way radio must be working and active prior to any 'on-track' activity.
- B. Two-way radios, crew-member to driver and/or any other means of electronic communication, other than the one-way radio, will not be permitted.
- C. Only approved transponders (lap timing and/or lap time recording devices) permitted (see each track's rules for more info).

### **General Car Inspection:**

All cars may be subject to technical inspection at any time. Any driver that fails to cooperate and/or allow an inspection of his car at any time will be subject to disqualification, a 45-day suspension, and \$750 fine. Note: In the event a part(s) must be removed for inspection, part(s) must be removed immediately by person(s) appointed by driver and/or car owner.

Full or partial car covers will be permitted only when there is inclement weather.

Rear car covers are permitted, but must be removed prior to leaving pit stalls. No covers of any kind under the car or covering wheel openings. Each team will receive one (1) verbal warning for the season. A second infraction will result in a loss of warm-ups, a loss of a qualifying lap, or placement to the tail of your next scheduled event, depending upon when said second infraction occurs.

## **FINES, PENALTIES, SUSPENSIONS & APPEALS**

### **PRE-RACE TECHNICAL VIOLATION:**

If a technical violation(s) is found during pre-race technical inspection, the driver/team will be advised of the violation and must meet full compliance before being allowed to compete.

### **REFUSAL OF TECH**

A refusal of tech and/or failure to allow an official to confiscate a part(s), other than the already previously stated individual refusal penalties/suspensions, will result in a 45-day suspension and \$750 fine. All illegal parts will be confiscated.

### **MULTIPLE INFRACTIONS:**

In the event driver and/or car is disqualified in post-race tech for the same technical rules infraction twice (excluding engines within the sealing system, tires, fuel, and shocks, springs, suspensions rules- see each rule for specific penalties), driver and car will be suspended for 7 days from all RUSH-sanctioned events. Each successive infraction will carry an additional 7-day suspension.

In the event an entrant fails technical inspection for multiple infractions that each carry a suspension and/or fine at the same event, suspension and/or fine will compound and accumulate with each infraction.

### **FINES & PENALTIES:**

If an entrant is disqualified for any reason, any fine and /or suspension applies to both the driver and car owner if not the same person. In other words, if an entrant is disqualified for a technical violation, such as an engine not in compliance with tech specs, neither the owner nor the driver can compete for the suspension period, and while only one fine will be charged, neither party can race until that fine is paid. Fine must be paid in full to Series by cash or certified check in order to compete once suspension period ends. NOTE: If suspension includes 'a number of days' clause and occurs at the end of the season when no additional events exist, suspension will carry over to the following year beginning with the first RUSH-sanctioned event in the region.

### **EVENT SUSPENSIONS:**

Owner suspended for any infraction will carry over to **ALL** RUSH-sanctioned divisions and will preclude owner from competing at **ANY** RUSH-sanctioned event until suspension is lifted. Driver suspended for any infraction will carry over to **ALL** RUSH-sanctioned divisions *unless* driver competes for a different car owner in other division(s). RUSH reserves the right to make judgment on a case-by-case basis and will have final say on eligibility to compete.

### **SPEEDWAYS CONTRACTING RUSH TO UTILIZE RUSH ENGINE SEALING SYSTEM:**

In the event an engine infraction occurs at a speedway that has contracted RUSH to *only* utilize the RUSH Engine Sealing System, imposed fines, penalties, suspensions, etc. *may* carry over to RUSH-sanctioned competition for driver and car owner. Contact RUSH for listing of speedways, which *only* utilizes the RUSH Engine Sealing System.

### **LEGALITY OF PARTS:**

If RUSH or Track Tech Inspector is unsure of the legality of a part, said part will be sent to GM or to RUSH Office for inspection. At this time, finishing position will be frozen until legality of said part is determined. In the event of a disqualification, finishing position, points and monies would be adjusted accordingly. **ALL ILLEGAL PARTS WILL BE CONFISCATED & DESTROYED!** Not allowing confiscating of parts is considered "cheating within the bolts" and said penalties will be imposed.

### **FINALITY OF DECISIONS AND INTERPRETATIONS AND COVENANT NOT TO SUE:**

The decisions of RUSH officials or promoter at an event, including the interpretation and application of rules and the scoring of positions, shall be FINAL, BINDING, and NON-APPEALABLE, except in the case of a suspension or fine, which is further explained in the SUSPENSIONS/FINES & APPEALS category.

All participants, as a condition of participating in an event, agree that ALL decisions of officials or the promoter, regarding the interpretation and application of the rules, and the scoring of positions, shall be NON-LITIGABLE. All participants further covenant and agree that they will NOT initiate any of legal action against Great Crate Racing Northeast D/B/A RUSH Racing Series, the promoter, and officials to challenge such decision, to seek monetary damages, to seek injunctive relief, or to seek any kind of legal remedy. If a participant pursues any such legal action, which violates this provision, then the participant and/or owner expressly agrees to reimburse RUSH for ALL of its ATTORNEY FEES and COSTS IN DEFENDING AGAINST SUCH LEGAL ACTION.

By signing the annual registration agreement, *or by participating in an event conducted under rules promulgated by or sanctioned by RUSH*, competitors agree that they will comply with all written rules and procedures of RUSH. In the event of a breach of any agreement or rules, competitor shall be liable for actual and liquidated damages sustained by RUSH Racing Series.

#### **APPEALS PROCESS:**

RUSH will determine any and all suspensions/fines that are covered in the rules and any violation that may come up during the year. RUSH will make judgment on the sanctions, and violator(s) will be sent official notice by a certified letter, return receipt requested.

Driver and/or car owner has the opportunity to appeal his or her sanction and must do so in writing accompanied by any relevant documentation. Appeal must be in writing and e-mailed to the RUSH Office at [info@rushracingseries.com](mailto:info@rushracingseries.com) within 48 hours of notification of violation.

RUSH will then set a date and time for the appeal hearing at the business office located at the address of 4368 Route 422, Pulaski, PA 16143. The violator(s) will present his/her case to the RUSH Racing Series. The violator(s) and one other person is permitted to attend the appeal hearing. Additional attendees must be approved by RUSH pursuant to a written request.

Following the appeal hearing with the violator(s), RUSH may conduct further follow-ups, meetings, etc. with any other necessary party(s). Judgment will then be rendered to the violator by a certified letter, return receipt.

Violator(s) agrees that the decision made will be final and party posting appeal has no legal rights thereafter. In the event of a protest, the party that protested also agrees to accept final ruling on decision and has no legal rights thereafter.

#### **MISREPRESENTATION**

False or inaccurate statements or information provided to RUSH in any instance(s) will render it void, and will excuse RUSH from any obligation created herein. Further, RUSH reserves the right to seek compensation for any damage suffered as a result of its reasonable reliance on the information provided.

Rev. 7/28/25

## Monte Carlo Door/Quarter Dimensions

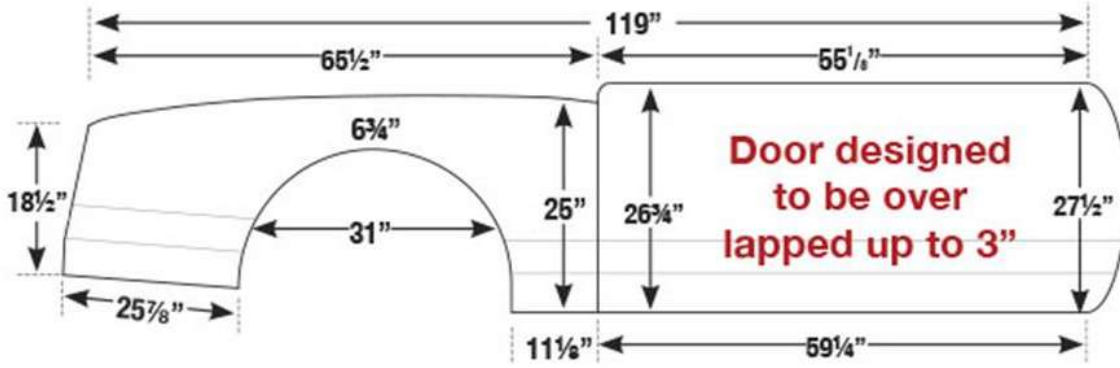

## Monte Carlo Hood Dimensions

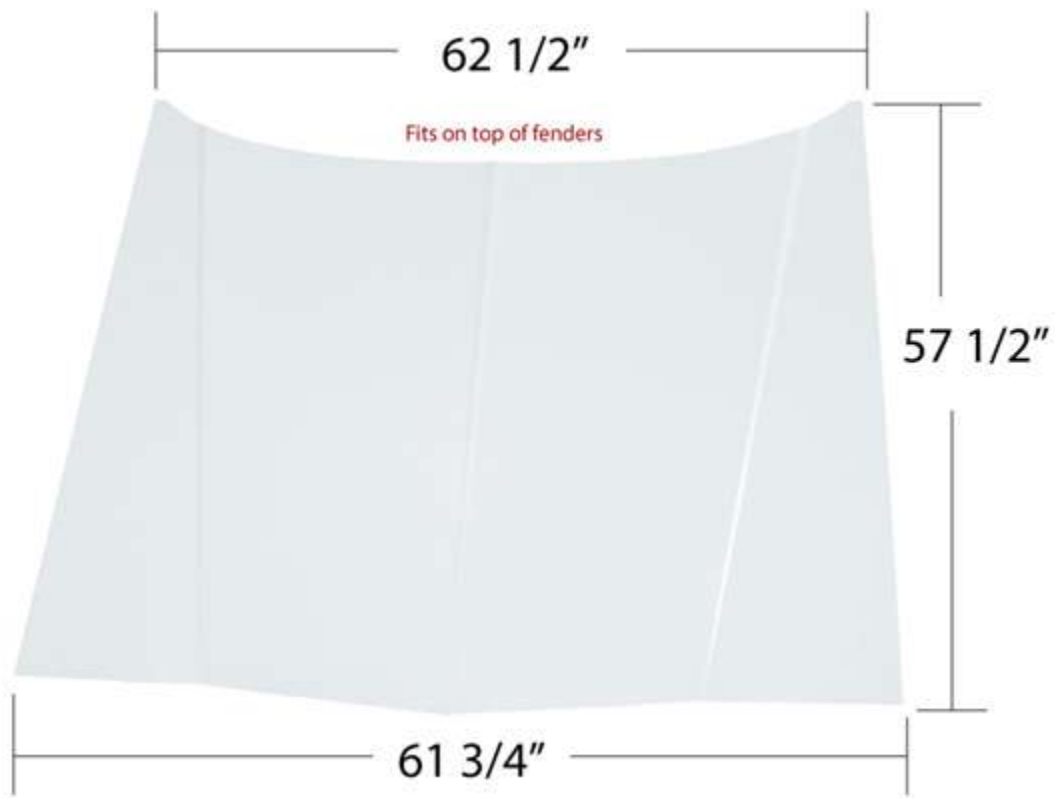

# Monte Carlo Roof Dimensions

Note: Performance Racing Bodies A-pillars Part #F1015-81W-A-L (left) & Part #F1015-81-W-A-R (right) are "highly recommended."



# Monte Carlo Trunk Dimensions

## One Piece

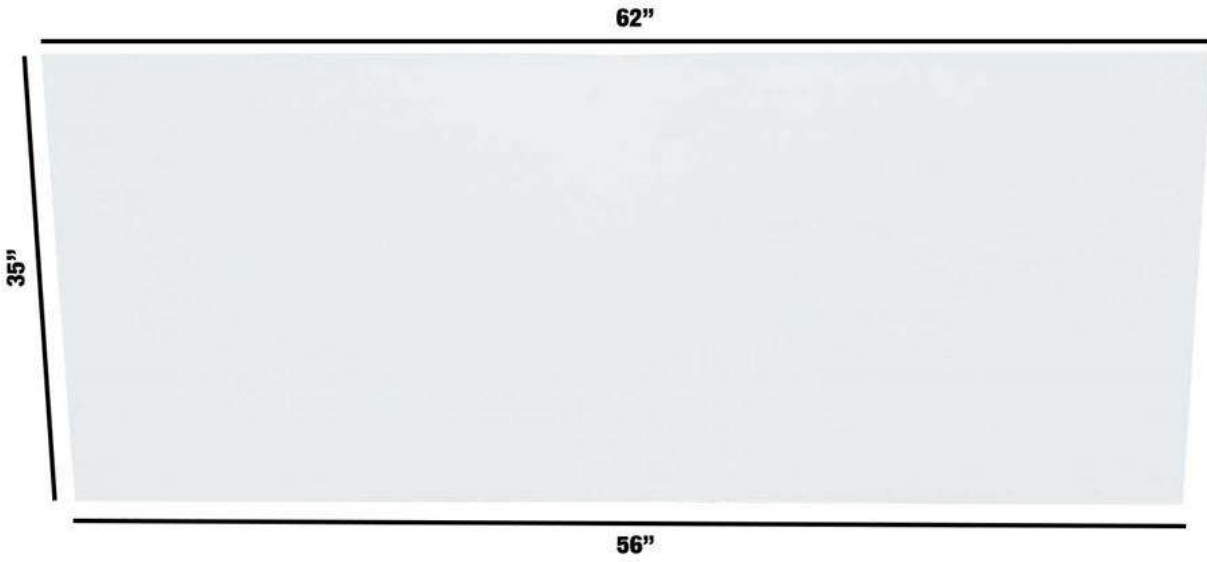

## Two Piece

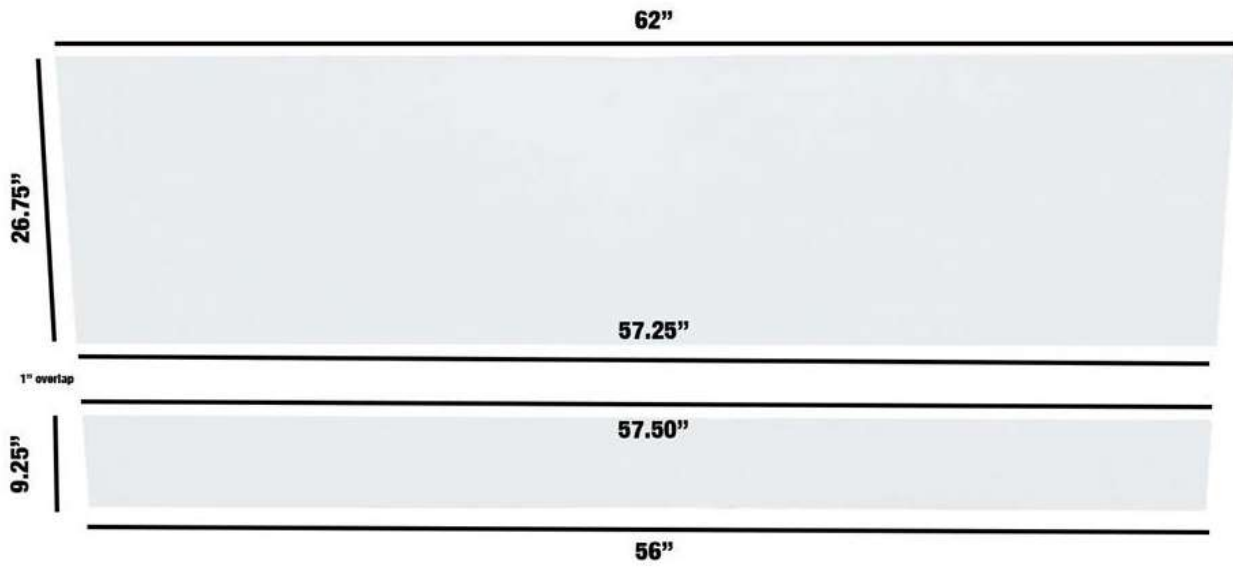



# STREET STOCK METRIC CHASSIS

## M • S E R I E S

Tubular steel chassis crafted to the same measurements as the classic OEM chassis.



Stock type 4-Link mounts.

**M SERIES  
OFFSET**



**M SERIES  
FULL PERIMETER**

Bernheisel Race Cars  
M•Series Street Stock is  
precision built to the specs  
of the 78-88 metric chassis.

Stock type  
steering box  
mounts.



- Crate Racin' USA approved!
- RUSH Stock Car Series approved!
- Safer and stronger
- Includes Jack Bolt Nuts and Spring Buckets.
- All stock components guaranteed to fit properly.
- Available with or without upper control arm mounts.
- Available in full perimeter or offset.
- Checking gauges available for tracks/series.



1 Bordnersville Rd. Jonestown, PA 17038

Call for more details 717.865.3119

[www.bernheiselracecars.com](http://www.bernheiselracecars.com)

### MD3 MONTE CARLO NOSE

- Molded ultra durable high-impact plastic
- Aerodynamically designed to maximize front down force
- 2-piece design with large overlap for easy assembly
- Increased front angle for increased down force
- Accepts existing Performance Bodies Headlight Decals
- Increase lay back for maximum aerodynamics

Nose w/ Decal Kit **\$184.00**      NOSE ONLY **\$164.00**



PART#	COLOR	DESCRIPTION	PRICE
MD3021-4101K	White	88 Monte Carlo Nose/Decal Combo - White	\$184.00
MD3021-4102K	Black	88 Monte Carlo Nose/Decal Combo - Black	\$184.00
MD3021-4103K	Red	88 Monte Carlo Nose/Decal Combo - Red	\$184.00
MD3021-4105K	Yellow	88 Monte Carlo Nose/Decal Combo - Yellow	\$184.00
MD3021-4106K	Orange	88 Monte Carlo Nose/Decal Combo - Orange	\$184.00
MD3021-4108K	Chevron Blue	88 Monte Carlo Nose/Decal Combo - Chevron Blue	\$184.00
MD3021-4109K	Gray	88 Monte Carlo Nose/Decal Combo - Gray	\$184.00

PART#	COLOR	DESCRIPTION	PRICE
MD3021-4101	White	88 Monte Carlo Nose - White	\$164.00
MD3021-4102	Black	88 Monte Carlo Nose - Black	\$164.00
MD3021-4103	Red	88 Monte Carlo Nose - Red	\$164.00
MD3021-4105	Yellow	88 Monte Carlo Nose - Yellow	\$164.00
MD3021-4106	Orange	88 Monte Carlo Nose - Orange	\$164.00
MD3021-4108	Chevron Blue	88 Monte Carlo Nose - Chevron Blue	\$164.00
MD3021-4109	Gray	88 Monte Carlo Nose - Gray	\$164.00

### MD3 UNIVERSAL NOSE WEAR STRIPS



- Made from heavy-duty molded plastic
- Sold in pairs
- Available in 10 colors

Fits MD3 88 Monte Carlo Nose and MD3 LMB Camaro nose

PART#	DESCRIPTION	PRICE
MD3021-400W	Wear Strip - White	\$45.00
MD3021-400B	Wear Strip - Black	\$45.00
MD3021-400R	Wear Strip - Red	\$45.00
MD3021-400Y	Wear Strip - Yellow	\$45.00
MD3021-400OR	Wear Strip - Orange	\$45.00
MD3021-400CB	Wear Strip - Chevron Blue	\$45.00
MD3021-400FR	Wear Strip - Fluorescent Red	\$45.00
MD3021-400FY	Wear Strip - Fluorescent Yellow	\$45.00
MD3021-400FO	Wear Strip - Fluorescent Orange	\$45.00
MD3021-400FG	Wear Strip - Fluorescent Green	\$45.00



### MD3 MONTE CARLO 2-PIECE BUMPER

- This 2-piece 'Slip-Fit' Design allows bumper to ship UPS! Weld or bolt together
- Tubing .083 wall



PART#	DESCRIPTION	PRICE
MD3MD1103	2-Piece Front Bumper - 88 MC	\$169.00

### MD3 MONTE CARLO NOSE SCREENS

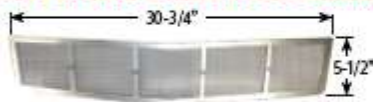

Part# MD3021-411SCR  
\$59.00

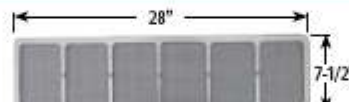

Part# FIV660411SCR  
\$55.00

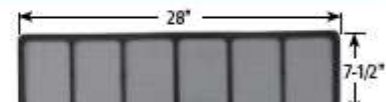

Part# FV660411B  
\$59.00

### 88 MONTE CARLO SS TAIL

- Molded ultra durable high-impact plastic
- Constructed of 2 pcs. (Right/Left) enables them to ship UPS, saving you money
- Will fit most aftermarket bodies
- Accepts existing Performance Bodies Taillight Decals

Tail w/ Decal Kit **\$184.00**      TAIL ONLY **\$164.00**



Taillight Sticker Kit (ONLY)  
Part# PER0T21  
\$24.95

#### MONTE CARLOS SS TAIL / DECAL COMBO

PART#	COLOR	DESCRIPTION	PRICE
PER2110K	White	Monte Carlo SS Tail/Decal Combo - White	\$184.00
PER2120K	Black	Monte Carlo SS Tail/Decal Combo - Black	\$184.00
PER2130K	Red	Monte Carlo SS Tail/Decal Combo - Red	\$184.00
PER2150K	Yellow	Monte Carlo SS Tail/Decal Combo - Yellow	\$184.00
PER2160K	Orange	Monte Carlo SS Tail/Decal Combo - Orange	\$184.00
PER21810K	Chevron Blue	Monte Carlo SS Tail/Decal Combo - Chev Blue	\$184.00
PER21910K	Gray	Monte Carlo SS Tail/Decal Combo - Gray	\$184.00

#### MONTE CARLO SS TAIL ONLY

PART#	COLOR	DESCRIPTION	PRICE
PER21100	White	Monte Carlo SS Tail ONLY - White	\$164.00
PER21200	Black	Monte Carlo SS Tail ONLY - Black	\$164.00
PER21300	Red	Monte Carlo SS Tail ONLY - Red	\$164.00
PER21500	Yellow	Monte Carlo SS Tail ONLY - Yellow	\$164.00
PER21600	Orange	Monte Carlo SS Tail ONLY - Orange	\$164.00
PER218100	Chevron Blue	Monte Carlo SS Tail ONLY - Chev Blue	\$164.00
PER219100	Gray	Monte Carlo SS Tail ONLY - Gray	\$164.00

FREE SHIPPING On Qualifying Orders Over \$99

**88 MONTE CARLO**

**PLATINUM PACKAGE**

- 2 Fenders
- 2 Fender Fillers
- 2 Doors
- 2 Stock Replacement Quarter Panels
- 2 Rocker Panels
- 88 Monte Carlo Fiberglass 2-PC Roof Kit
- Monte Carlo SS Nose
- Monte Carlo SS Tail
- Nose Decal Kit
- Taillight Decals
- 88 Monte Carlo Hood
- 88 Monte Carlo Trunk Lid



**\$1,999<sup>00</sup>**

Part# PBO217014

**ULTIMATE DELUXE PACKAGE**

- 2 Fenders
- 2 Fender Fillers
- 2 Doors
- 2 Stock Replacement Quarter Panels
- 2 Rocker Panels
- Monte Carlo SS Nose
- Monte Carlo SS Tail
- Nose Decal Kit
- Taillight Decals



**\$1,425<sup>00</sup>**

Part# PBO217013

**DELUXE PACKAGE**

- 2 Fenders
- 2 Fender Fillers
- 2 Doors
- 2 Lower Quarters (2 pc design)
- 2 Rocker Panels
- Monte Carlo SS Nose
- Monte Carlo SS Tail
- Nose Decal Kit
- Taillight Decals

**\$1,075<sup>00</sup>**

Part# PBO217012

**ULTIMATE SHORT TRACK PACKAGE**

- 2 Fenders
- 2 Fender Fillers
- 2 Doors
- 2 Stock Replacement Quarter Panels



**\$999<sup>00</sup>**

Part# PBO217018

**FRONT CLIP PACKAGE**

- 2 Fenders
- 2 Fender Fillers
- 2 Doors
- Nose piece and Deluxe Headlight Decal Kit

**\$635<sup>00</sup>**

Part# PBO217011

**SHORT TRACK PACKAGE**

- 2 Fenders
- 2 Fender Fillers
- 2 Doors
- 2 Lower Quarters (2 pc design)

**\$625<sup>00</sup>**

Part# PBO217008

**ATTENTION:**

Performance Bodies has IMCA APPROVED door skins, fenders, lower quarters, and lower rockers for your GM metric car. The approved body panels are steel.

*MONTE CARLO BODIES AVAILABLE IN STEEL 24-GAUGE BLACK*

DESCRIPTION	PART #	PRICE
MD3 Monte Carlo Nose	MD3021-410X	\$164.00
Monte Carlo Tail	PER21X100	\$164.00
Stock Replacement Right Fender	PER21701R	\$135.00
Stock Replacement Left Fender	PER21701L	\$135.00
Right Fender Filler	PBO21723RB	\$12.99
Left Fender Filler	PBO21723LB	\$12.99
Manufactured Right Door	PBO21702RB	\$90.00
Manufactured Left Door	PBO21702LB	\$90.00
Manufactured Lower 1-Piece Right Quarter	PBO21703RB	\$90.00
Manufactured Lower 1-Piece Left Quarter	PBO21703LB	\$90.00
Stock Replacement Right Quarter	PER21703RS	\$279.00
Stock Replacement Left Quarter	PER21703LS	\$279.00
Manufactured Lower 2-Piece Right Quarter	PBO21713RB	\$90.00
Manufactured Lower 2-Piece Left Quarter	PBO21713LB	\$90.00
Manufactured Rocker Panel - (Each)	PBOMC7310B	\$44.99

• SEE PAGE 11 FOR MONTE CARLO NOSE'S & TAIL'S  
 • SEE PAGE 13 FOR HOODS, ROOF, AND TRUNK LID'S

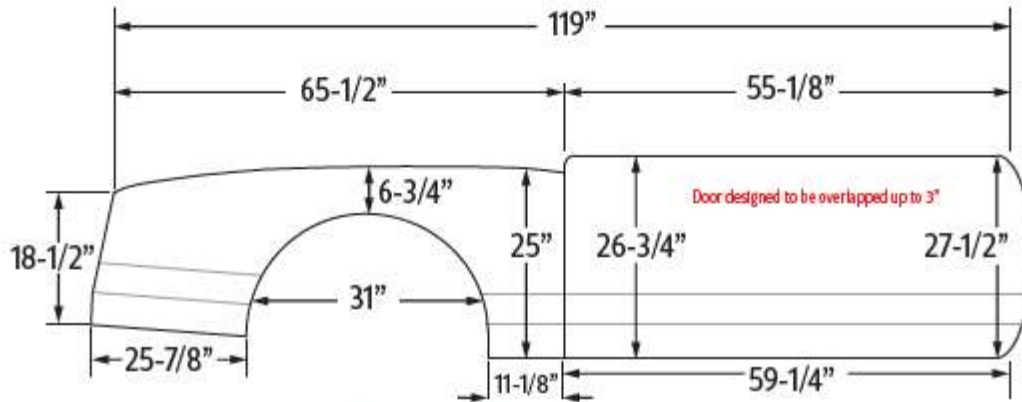



**TUCKER RICHARDSON**  
MORNING SUN, IA



Stock Replacement Quarter Panel  
Part #PER21703LS OR RS  
**\$279.00**

Performance Bodies manufactured body panels are template made from 24-gauge black steel

X = L for LEFT or R for RIGHT



Manufactured 1-Piece Lower Quarter  
Part# PBO21703XB  
**\$90.00**

Manufactured Door  
Part# PBO21702XB  
**\$90.00**

Stock Replacement Fender  
Part# PER21701X  
**\$135.00**

Fender Filler  
Part# PBO21723XB  
**\$12.99**

Trim your stock quarter panel 2" below body line, then install NEW LOWER QUARTER.

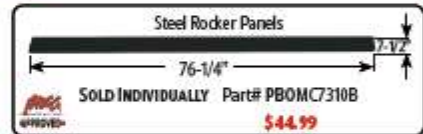

**88 MONTE CARLO HOODS, ROOFS & TRUNK LIDS**

**88 MONTE CARLO MANUFACTURED TRUNK LID**

2-Piece & 1-Piece Trunk Lid Available

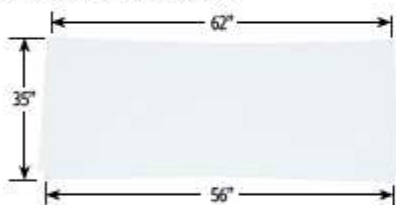

\* 1-Piece must ship truck freight

**88 MONTE CARLO FIBERGLASS 2-PC ROOF KIT**

Kit includes front A-Pillars

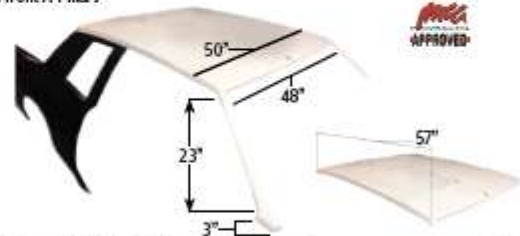

1-PIECE PART#	2-PIECE PART#	COLOR	DESCRIPTION	PRICE
PBO21121	PBO21221	White Aluminum	White Aluminum	<b>\$94.99</b>
PBO219121	PBO219221	Gloss Black Aluminum	Gloss Black Aluminum	<b>\$94.99</b>
PBO217121B	PBO217221B	Black Steel	Black Steel	<b>\$94.99</b>

1-PIECE PART#	DESCRIPTION	PRICE
PRPF1015-81W	Roof Kit - White	<b>\$369.99</b>
PRPF1015-81W-A-L	Replacement A-Pillar - White - Left	<b>\$76.99</b>
PRPF1015-81W-A-R	Replacement A-Pillar - White - Right	<b>\$76.99</b>

**88 MONTE CARLO MANUFACTURED HOOD**

Factory Back

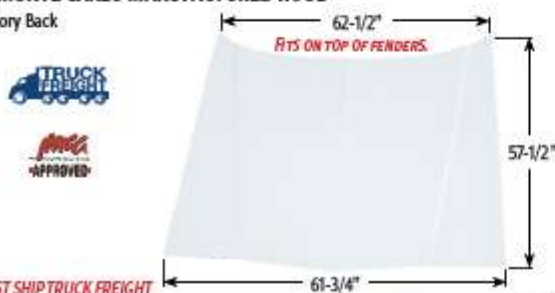

MUST SHIP TRUCK FREIGHT

PART #	COLOR	DESCRIPTION	PRICE
PBO211550	White Aluminum	White Aluminum	<b>\$154.99</b>
PBO219550	Gloss Black Aluminum	Gloss Black Aluminum	<b>\$154.99</b>
PBO217550B	Black Steel	Black Steel	<b>\$154.99</b>

**88 MONTE CARLO MANUFACTURED HOOD**

Squared Back

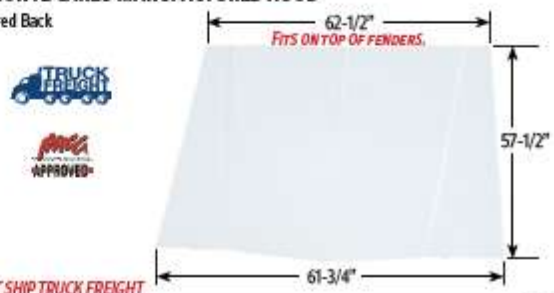

MUST SHIP TRUCK FREIGHT

PART #	COLOR	DESCRIPTION	PRICE
PBO211550	White Aluminum	White Aluminum	<b>\$154.99</b>
PBO219550	Gloss Black Aluminum	Gloss Black Aluminum	<b>\$154.99</b>
PBO217550B	Black Steel	Black Steel	<b>\$154.99</b>

FREE SHIPPING On Qualifying Orders Over \$99

## Approved Performance Bodies '88 Monte Carlo Aftermarket Body Part #s

PRP1015-81W	88 Monte Carlo 2pc Fiberglass Roof Kit
PER21701R	Replacement Fender Right
PER21701L	Replacement Fender Left
PBO21702R	Door-steel right
PBO21702R	Door-steel left
PER21703RS	Stock Replacement Qtr Right
PER21703LS	Stock Replacement Qtr Left
PBO21703L	Manufactured Lower Quarter Left
PBO21703R	Manufactured Lower Quarter Right
PBO217310	88 Monte Carlo Rockers steel
PBO21723R	Fender Filler Right
PBO21723L	Fender Filler Left
MD3021-4101	MD3 88 Monte Carlo nose White
MD3021-4102	MD3 88 Monte Carlo nose Black
MD3021-4103	MD3 88 Monte Carlo nose Red
MD3021-4105	MD3 88 Monte Carlo nose Yellow
MD3021-4106	MD3 88 Monte Carlo nose Orange
MD3021-4108	MD3 88 Monte Carlo nose Chevron Blue
PER211100	MD3 88 Monte Carlo Tail White
PER212100	MD3 88 Monte Carlo Tail Black
PER213100	MD3 88 Monte Carlo Tail Red
PER215100	MD3 88 Monte Carlo Tail Yellow
PER216100	MD3 88 Monte Carlo Tail Orange
PER218100	MD3 88 Monte Carlo Tail Chevron Blue
PBO211120	88 Monte Carlo Trunk Lid White Aluminum
PBO219120	89 Monte Carlo Trunk Lid Gloss Black Aluminum
PBO21R120	88 Monte Carlo Trunk Lid Red Aluminum
PBO21Y120	88 Monte Carlo Trunk Lid Yellow Aluminum
PBO21C120	88 Monte Carlo Trunk Lid Chevron Blue Aluminum
PBO217120	88 Monte Carlo Trunk Lid Steel White
PBO210120	88 Monte Carlo Trunk Lid Flat Black Aluminum
PBO211550	88 Monte Carlo Manufactured Hood White Aluminum
PBO219550	88 Monte Carlo Manufactured Hood Gloss Black Aluminum
PBO217550	88 Monte Carlo Manufactured Hood Steel White
PER887050	88 Monte Carlo Stock Replacement Hood Skin Only
M1125	MD3 Rocker Panel White
M1225	MD3 Rocker Panel Black
M1325	MD3 Rocker Panel Red
M1525	MD3 Rocker Panel Yellow
M1625	MD3 Rocker Panel Orange
M1825	MD3 Rocker Panel Chevron Blue
M11025F	MD3 Rocker Panel Fluorescent Yellow
M11125F	MD3 Rocker Panel Fluorescent Orange
M11225F	MD3 Rocker Panel Fluorescent Green
M11325F	MD3 Rocker Panel Fluorescent Red